

SOVETITALIA



PRICE LIST - NEW SHAPES

PRODOTTI

PRODUCTS

3FEET, AIKIDO, BRIDGE, CRICKET,
CROSS, DOGE, FLÛTE, FROG,
GENIUS, HUG, JEAN, LAMBDA,
LIVE, NIDO, PALACE, PARTY, RING,
RUBINO, SHELL, SLIM, SPIDER,
SWAN, TAKY, TORONTO, TOTEM,
TULIP, VALENCIA, BOSTON,
DENVER, ENDLESS, FIORDIVETRO,
GOCCE DI RUGIADA, HORIZON,
ICE ROCK, LEGO, MIIR, SEGMENT,
TEMIRA, VERTIGO, WAVE, DELPHI,
DOX, OLYMPIA, TOBY, ZETA,
BUGATTI, GLOVE, SILLA

INDICE PRODOTTI
PRODUCTS INDEX

Tavoli /
dining tables /



AIKIDO pag. 9



AIKIDO TWO BASES pag. 8



ARTIKO pag. 13



BRIDGE pag. 14



CROSS pag. 22



CROSS wood pag. 24



DOGE pag. 25



FLÔTE pag. 27



FLÔTE wood pag. 30



FROG pag. 34



JEAN pag. 36



LAMBDA pag. 41



LAMBDA TWO BASES pag. 44



PARTY pag. 50



PALACE pag. 45



PALACE EXTENSIBLE pag. 48



PALACE wood pag. 47



PARTY pag. 50



SLIM pag. 55



SLIM wood pag. 61



SLIM CIRCLES pag. 57



SLIM CERAMIC pag. 64



SLIM EXTENSIBLE pag. 56/60/63/65



TORONTO pag. 73



TOTEM pag. 74



TOTEM wood pag. 76



TOTEM TWO BASES pag. 81



TOTEM EXTENSIBLE pag. 82



VALENCIA pag. 88



VALENCIA EXTENSIBLE pag. 89

Tavolini /
coffee tables /



3 FEET pag. 90



BRIDGE pag. 15



FLÔTE pag. 31



FLÔTE WOOD pag. 33



FLÔTE CIRCLES pag. 33



FROG pag. 35



GENIUS pag. 91



GENIUS WOOD pag. 93



GENIUS CIRCLES pag. 91



HUG pag. 94



JEAN pag. 38



NIDO pag. 95



PALACE pag. 49



PARTY pag. 53



RING pag. 97



RUBINO pag. 99



SHELL pag. 102



SLIM pag. 66



SLIM WOOD pag. 68



SLIM CIRCLES pag. 68



SLIM CERAMIC pag. 66



SPIDER pag. 101



SWAN pag. 104



TAKY pag. 100



TOTEM pag. 83



TOTEM WOOD pag. 87



TULIP pag. 106



TULIP WOOD pag. 108



TULIP CIRCLES pag. 106

Console / console /



BRIDGE pag. 20



CRICKET pag. 129



NIDO pag. 96



SLIM pag. 70



SLIM wood pag. 72



SLIM CERAMIC pag. 70

Sedie / chairs /



BUGATTI pag. 137



FLÔTE pag. 138



FLÔTE GIREVOLE pag. 139



GLOVE GIREVOLE pag. 140



GLOVE pag. 141



SILLA pag. 142



TOTEM pag. 145

Complementi / Accessories /



DELPHI pag. 130



OLYMPIA pag. 132



DOX pag. 135



SCREEN pag. 133



TOBY pag. 134



ZETA pag. 136

Specchiere /
mirrors /



BOSTON pag. 109



DENVER pag. 111



ENDLESS pag. 114

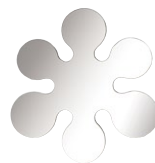

FIORDIVETRO pag. 115



GOCCE DI RUGIADA pag. 116



HORIZON pag. 117



ICE ROCK pag. 119



LEGO pag. 120



MIR pag. 121

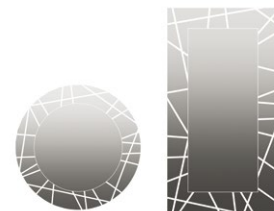

SEGMENT pag. 123



SPOT pag. 125



TEMIRA pag. 128



VERTIGO pag. 126

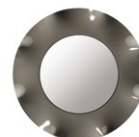

WAVE pag. 127

Finiture/
Finishes /

pag.151



VETRO - GLASS



LEGNO - WOOD



ALLUMINIO & METALLO- ALUMINIUM & METAL

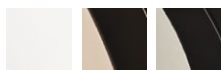

SPECCHIO - MIRROR



HPL - HPL

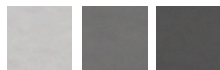

CERAMICA - CERAMIC



PELLI - LEATHERS

Condizioni di vendita/
Sale conditions /

pag.158

AIKIDO - TWO BASES H. 74

design Studio Sovet
2012

Tavolo con basi in legno, varie finiture, o in metallo cromato lucido. Top in vetro temperato trasparente, disponibile anche nella versione laccata, vari colori.

Dining table with wooden bases, various finishes, or in polished chrome metal. Tempered clear glass top available also in the lacquered version, various colours.

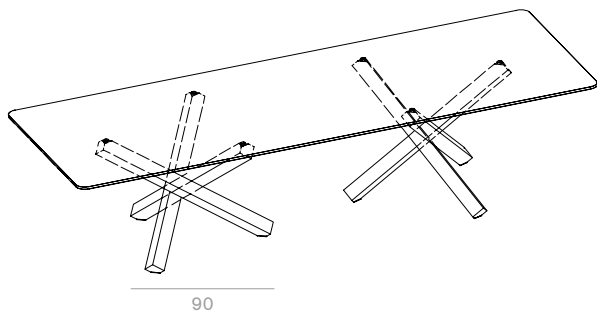

DIMENSIONS cm	TOP	BASE	COD.	M ³	KG
320x120	15 FL	WG/BI/NC	P1380 _ _ _	0,32	186
		LC	P1380LC _ _	0,32	218
320x120	8+8 ★	WG/BI/NC	P1382 _ _ _	0,32	186
		LC	P1382LC	0,32	218



FINITURE TOP / TOP FINISHES

VETRO FLOAT CLEAR GLASS		VETRO EXTRACHIARO EXTRALIGHT GLASS		FUMÉ /BRONZO SMOKED / BRONZED
Clear TRTR	Lacquered Cat. A / C	Extralight TETE	Lacquered Cat. B / D	Laminate 8+8 Sp. 16
€	€	€	€	
3030	3550	3440	3960	-
3710	4230	4120	4640	-
-	-	-	-	3440
-	-	-	-	4120

FINITURE BASE / BASE FINISHES

Cromo lucido / Polished chrome



LC

Legno / Wood



WG

BI

NC

★ Top in vetro stratificato mm 8 + 8

★ Top in laminated glass mm 8 + 8

Top in appoggio.

Top not fixed to the base.



TRTR



TRB2

TRC1



TRN1



TRN2



TRR1



TRMP



TRM1



TRM2

TRM3



TETE



TEA1

TEB1



TEC2



TER2



TER3



TEV1



TEM4



TEM5

TES1



TTF ★



TBTB ★

AIKIDO - SQUARE H. 74

design Studio Sovet
1995

Tavolo con base in legno, varie finiture, o in metallo cromato lucido. Top in vetro temperato trasparente, disponibile anche nella versione laccata, vari colori.

Dining table with wooden base, various finishes, or in polished chrome metal. Tempered clear glass top, available also in the lacquered version, various colours.

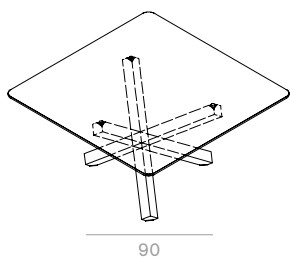

DIMENSIONS cm	TOP	BASE	COD.	M ³	KG
140x140	15 FL	WG/BI/NC	P1354 _ _ _	0,16	95
		LC	P1354LC _ _	0,16	111

FINITURE TOP / TOP FINISHES

VETRO FLOAT CLEAR GLASS		VETRO EXTRACHIARO EXTRALIGHT GLASS	
Clear TRTR	Lacquered Cat. A / C	Extralight TETE	Lacquered Cat. B / D
€	€	€	€
1560	1820	1770	2040
1860	2120	2070	2340

FINITURE BASE / BASE FINISHES

Cromo lucido / Polished chrome



LC

Legno / Wood



WG

BI

NC

Top fissato alla base tramite placche in inox.

Top fixed to the base through steel plates.



TRTR



TRB2

TRC1

TRN1

TRN2

TRR1

TRMP

TRM1

TRM2

TRM3



TETE



TEA1

TEB1

TEC2

TER2

TER3

TEV1

TEM4

TEM5

TES1

AIKIDO - ROUND H. 74

design Studio Sovet
1995

Tavolo con base in legno, varie finiture, o in metallo cromato lucido. Top in vetro temperato, trasparente o acidato, disponibile anche nella versione laccata, vari colori.

Dining table with wooden base, various finishes, or in polished chrome metal. Tempered glass top, clear or frosted, available also in the lacquered version, various colours.

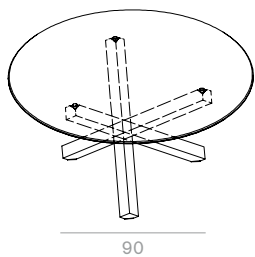

90

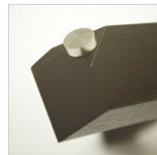

Ø 170



Ø 130/140/150

DIMENSIONS cm	TOP	BASE	COD.	M ³	KG
Ø 130	12 FL45°	WG/BI/NC	P1367 _ _ _	0,15	60
		LC	P1367LC _ _	0,15	76
Ø 140	12 FL45°	WG/BI/NC	P1352 _ _ _	0,16	67
		LC	P1352LC _ _	0,16	83
Ø 150	12 FL45°	WG/BI/NC	P1366 _ _ _	0,18	75
		LC	P1366LC _ _	0,18	91
Ø 170	12 FL45°	WG/BI/NC	P1358 _ _ _	0,22	93
		LC	P1358LC _ _	0,22	109

FINITURE BASE / BASE FINISHES

Cromo lucido / Polished chrome



LC

Legno / Wood



WG

BI

NC

Il top è sempre fissato alla base mediante delle placche nella versione cromo lucido, mentre solo nei diametri superiori a 150 cm. nella versione in legno.

The top is always fixed to the base through some metal plates as for the polished chrome version, while only tops bigger than Ø 150 cm. as for the wooden version.

FINITURE TOP / TOP FINISHES

VETRO FLOAT CLEAR GLASS		ACIDATO FROSTED			
Clear TRTR	Lacquered Cat. A / C	Glass TETE / TETF	Lacquered Cat. B / D	Frosted AEAE	Lacquered Cat. E
€	€	€	€	€	€
1240	1520	1370	1660	1470	1750
1620	1820	1750	1960	1850	2050
1310	1630	1460	1780	1570	1890
1690	1930	1840	2080	1950	2190
1380	1730	1550	1910	1690	2040
1760	2030	1930	2210	2070	2340
1560	1990	1780	2220	1950	2380
1920	2270	2140	2500	2310	2660

TRTR	TRB2	TETE	TEA1	AEAE	AEA1
	TRC1	TETF	TEB1		AEB1
	TRN1		TEC2		AEC1
	TRN2		TER2		AEC2
	TRR1		TER3		
	TRMP		TEV1		
	TRM1		TEM4		
	TRM2		TEM5		
	TRM3		TES1		

AIKIDO - ELLIPTICAL H. 74

design Studio Sovet
1995

Tavolo con base in legno, varie finiture, o in metallo cromato lucido. Top in vetro temperato, trasparente o acidato, disponibile anche nella versione laccata, vari colori.

Dining table with wooden base, various finishes, or in polished chrome metal. Tempered glass top, clear or frosted, available also in the lacquered version, various colours.

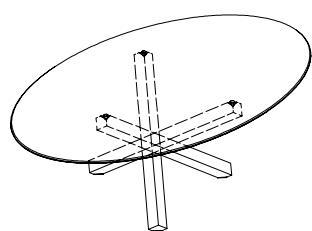

90



DIMENSIONS cm	TOP	BASE	COD.	M ³	KG	FINITURE TOP / TOP FINISHES					
						VETRO FLOAT CLEAR GLASS		ACIDATO FROSTED			
						Clear TRTR	Lacquered Cat. A / C	Glass TETE / TETF	Lacquered Cat. B / D	Frosted AEAE	Lacquered Cat. E
						€	€	€	€	€	€
180x130	12 FL45°	WG/BI/NC	P1364 _ _ _	0,19	78	1400	1770	1580	1950	1720	2090
		LC	P1364LC _ _	0,19	94	1780	2070	1960	2250	2100	2390
220x130	12 FL45°	WG/BI/NC	P1356 _ _ _	0,22	92	1560	1980	1780	2200	1940	2370
		LC	P1356LC _ _	0,22	108	1920	2260	2140	2480	2300	2650

FINITURE BASE / BASE FINISHES

Cromo lucido / Polished chrome



LC

Legno / Wood

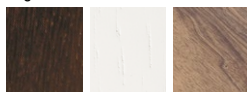

WG

BI

NC

Top fissato alla base tramite placche in inox.

Top fixed to the base through steel plates.

					
TRTR	TRB2	TETE	TEA1	AEAE	AEA1
	TRC1		TEB1		AEB1
	TRN1		TEC2		AEC1
	TRN2	TETF	TER2		AEC2
	TRR1		TER3		
	TRMP		TEV1		
	TRM1		TEM4		
	TRM2		TEM5		
	TRM3		TES1		

AIKIDO - POLYGONAL H. 74

design Studio Sovet
1995

Tavolo con base in legno, varie finiture, o in metallo cromato lucido. Top in vetro temperato trasparente, disponibile anche nella versione laccata, vari colori.

Dining table with wooden base, various finishes, or in polished chrome metal. Tempered clear glass top, available also in the lacquered version, various colours.

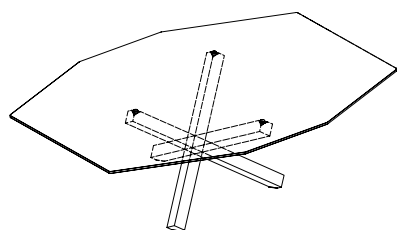

DIMENSIONS cm	TOP	BASE	COD.	M ³	KG
 240x140x74h	15 FL	WG/BI/NC	P1368 _ _ _	0,25	117
		LC	P1368LC _ _	0,25	133

FINITURE TOP / TOP FINISHES

VETRO FLOAT CLEAR GLASS		VETRO EXTRACHIARO EXTRALIGHT GLASS	
Clear TRTR	Lacquered Cat. A / C	Extralight TETE	Lacquered Cat. B / D
€	€	€	€
2020	2470	2380	2840
2300	2750	2660	3120

FINITURE BASE / BASE FINISHES

Cromo lucido / Polished chrome



LC

Legno / Wood

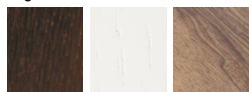

WG

BI

NC

Top fissato alla base tramite placche in inox.

Top fixed to the base through steel plates.



TRTR



TRB2

TRC1

TRN1

TRN2

TRR1

TRMP

TRM1

TRM2

TRM3



TETE



TEA1

TEB1

TEC2

TER2

TER3

TEV1

TEM4

TEM5

TES1

ARTIKO - H. 74

design Mara Panizzo
2010

Tavolo con base in vetro incollato trasparente o extrachiaro e top poligonale in vetro temperato trasparente, trasparente extrachiaro o laccato, varie finiture.

*Dining table with glued base in clear or extraclear glass.
Polygonal tempered top in clear, extralight or lacquered glass,
various finishes.*

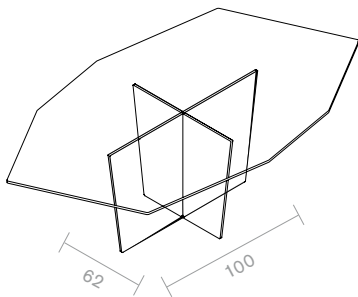
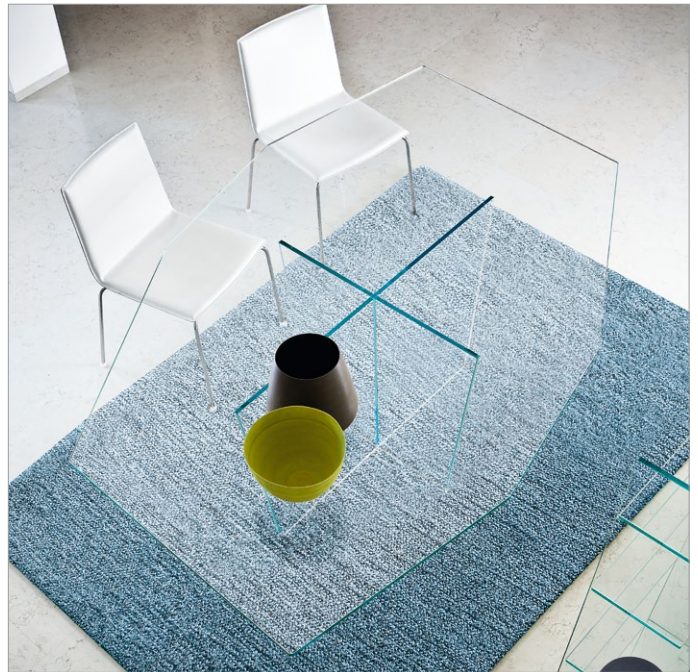

DIMENSIONS cm	TOP	BASE	COD.	M ³	KG
240x140x74h	15 FL Temp.	TR	P1060TR _ _	0,88	163
240x140x74h	15 FL Temp.	TE	P1060TE _ _	0,88	163

FINITURE TOP / TOP FINISHES

VETRO FLOAT CLEAR GLASS		VETRO EXTRACHIARO EXTRALIGHT GLASS	
Clear TRTR	Lacquered Cat. A / C	Extralight TETE	Lacquered Cat. B / D
€	€	€	€
1860	2310	-	-
-	-	2390	2850

FINITURE BASE / BASE FINISHES

Vetro float / Clear glass



TRTR

Vetro extrachiaro / Extralight glass



TETE



TRTR



TRB2



TRC1



TRN1



TRN2



TRR1



TRMP



TRM1



TRM2



TRM3



TETE



TEA1



TEB1



TEC2



TER2



TER3



TEV1



TEM4



TEM5



TES1

BRIDGE - ORDER H. 74

design Studio Sovet
1988

Tavolo / scrivania in vetro curvato trasparente, trasparente extrachiaro o laccato mono o bicolore, vari colori.

Writing desk in clear, extralight or lacquered mono or two-tones bent glass, various colours.

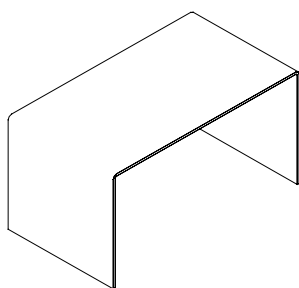

FINITURE TOP / TOP FINISHES

DIMENSIONS cm	SP. / TH.	COD.	M ³	KG	VETRO FLOAT CLEAR GLASS			VETRO EXTRACHIARO EXTRALIGHT GLASS		
					Clear TRTR	Lacquered Cat. A	Two-tones Cat. A or C	Extralight TETE	Lacquered Cat. B	Two-tones Cat. B or D
					€	€	€	€	€	€
125x70	15	P1210 _ _	0,89	98	1000	1300	1380	1200	1500	1590
138x78	15	P1211 _ _	1,08	111	1160	1500	1600	1400	1750	1850



TRTR

TRB2



TRC1



TRN1



TRN2



TRR1



TRMP



TRB2



TRC1



TRN1



TRN2



TRR1



TRMP



TRM1 *



TRM2 *



TRM3 *



TETE

TEA1



TEB1



TEC2



TER2



TER3



TEV1



TEA1 *



TEB1



TEC2



TER2



TER3



TEV1



TEM4 *



TEM5 *

TES1 *

* I colori contrassegnati possono essere utilizzati solo per il lato esterno e devono essere sempre protetti internamente da un secondo colore.

* The marked colours can only be used on the external side and need to be protected by a second internal colour.

BRIDGE - TRIX

design Studio Sovet
1988

Tavolino in vetro curvo trasparente,
trasparente extrachiario, placcato o laccato
mono o bicolore.

*Clear, extralight, plated or lacquered mono
or two-tones, bent glass coffee table.*

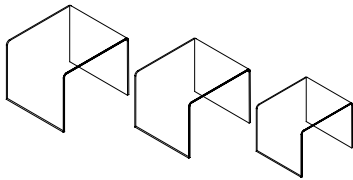
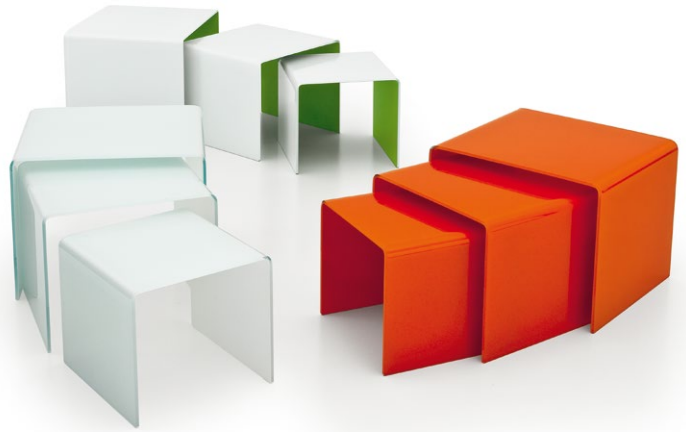

FINITURE TOP / TOP FINISHES

DIMENSIONS cm	SP. / TH.	COD.	M ³	KG	VETRO FLOAT CLEAR GLASS			VETRO EXTRACHIARIO EXTRALIGHT GLASS			
					Clear TRTR	Lacquered Cat. A	Two-tones Cat. A or C	Extralight TETE	Lacquered Cat. B	Two-tones Cat. B or D	Plated Cat. P
					€	€	€	€	€	€	€
56x49x43h	10	P4130 _ _	0,16	20	210	320	350	280	380	410	640
48x44x39h	10	P4131 _ _	0,11	16	180	270	290	220	310	330	520
40x40x35h	10	P4132 _ _	0,08	13	150	220	240	180	250	270	420
Set completo / Complete set	10	P4129 _ _	0,16	45	500	750	820	640	890	960	1500



TRTR

TRB2

TRC1

TRN1

TRN2

TRR1

TRMP

TRB2

TRC1

TRN1

TRN2

TRR1

TRMP

TRM1 *

TRM2 *

TRM3 *



TETE

TEA1

TEB1

TEC2

TER2

TER3

TEV1

TEA1 *

TEB1

TEC2

TER2

TER3

TEV1

TEM4 *

TEM5 *

TES1 *



TEYO



TEYA



TEYR

* I colori contrassegnati possono essere utilizzati solo per il lato esterno e devono essere sempre protetti internamente da un secondo colore.

* The marked colours can only be used on the external side and need to be protected by a second internal colour.

BRIDGE - RECTANGULAR

design Studio Sovet
1988

Tavolino in vetro curvo trasparente, trasparente extrachiaro, placcato o laccato mono o bicolore.

Clear, extralight, plated or lacquered mono or two-tones, bent glass coffee table.

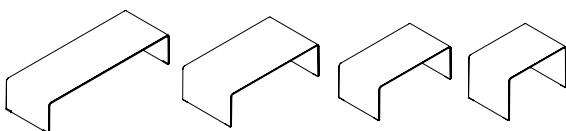

DIMENSIONS cm	SP. / TH.	COD.	M ³	KG
72x50x45h	12	P4098 _ _	0,22	28
90x50x36h	12	P4099 _ _	0,22	28
90x60x46h	12	P4101 _ _	0,32	37
110x60x36h	12	P4102 _ _	0,31	36
110x70x46h	12	P4103 _ _	0,44	49
130x70x36h	12	P4106 _ _	0,43	49
130x53x42h	15	P4107 _ _	0,40	48
110x55x23h	15	P5704 _ _	0,20	35
150x53x32h	15	P4114 _ _	0,37	48
150x70x47h	15	P4115 _ _	0,64	74

FINITURE TOP / TOP FINISHES

VETRO FLOAT CLEAR GLASS			VETRO EXTRACHIARO EXTRALIGHT GLASS			
Clear TRTR	Lacquered Cat. A	Two-tones Cat. A or C	Extralight TETE	Lacquered Cat. B	Two-tones Cat. B or D	Plated Cat. P
€	€	€	€	€	€	€
280	420	450	340	480	520	740
280	420	450	340	480	520	740
360	550	600	440	630	670	970
360	550	600	440	630	670	970
470	700	770	580	810	880	1260
470	700	770	580	810	880	1260
480	680	730	600	800	850	1160
380	530	570	460	610	650	880
480	680	730	600	800	850	1160
740	1050	1120	920	1230	1300	1760



TRTR

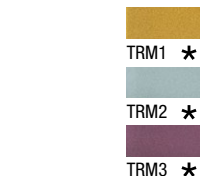

TETE

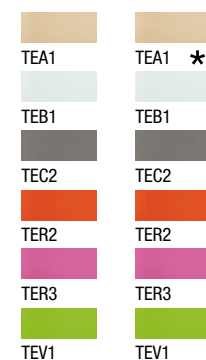

★ I colori contrassegnati possono essere utilizzati solo per il lato esterno e devono essere sempre protetti internamente da un secondo colore.

★ The marked colours can only be used on the external side and need to be protected by a second internal colour.

BRIDGE - SQUARE

design Studio Sovet
1988

Tavolino in vetro curvo trasparente, trasparente extrachiaro, placcato o laccato mono o bicolore.

Clear, extralight, plated or lacquered mono or two-tones, bent glass coffee table.

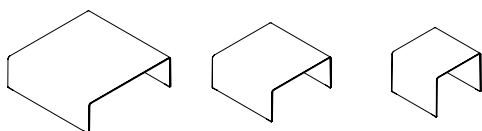
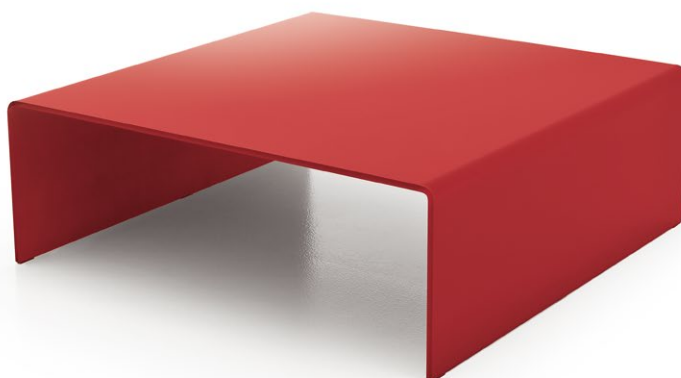

DIMENSIONS cm	SP. / TH.	COD.	M ³	KG
60x60x46h	10	P4120 _ _	0,22	26
80x80x36h	12	P4122 _ _	0,30	40
110x110x36h	12	P4126 _ _	0,55	61

FINITURE TOP / TOP FINISHES

VETRO FLOAT CLEAR GLASS			VETRO EXTRACHIARO EXTRALIGHT GLASS			
Clear TRTR	Lacquered Cat. A	Two-tones Cat. A or C	Extralight TETE	Lacquered Cat. B	Two-tones Cat. B or D	Plated Cat. P
€	€	€	€	€	€	€
280	440	480	350	510	550	800
410	610	670	500	700	760	1090
670	1000	1080	810	1140	1230	1770



TRTR

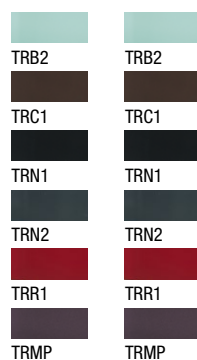

TETE



TEYO



TEYA



TEYR

* I colori contrassegnati possono essere utilizzati solo per il lato esterno e devono essere sempre protetti internamente da un secondo colore.

* The marked colours can only be used on the external side and need to be protected by a second internal colour.

BRIDGE - WITH DRAWER AND SHELF

design Studio Sovet
2013

Tavolino in vetro curvato trasparente o trasparente extrachiario con ripiano in vetro. Cassettera in noce canaletto, bianco poro aperto o wengé.

Coffee table in clear or extralight bent glass with glass shelf. White opened pores, wengé or canaletto walnut drawer.

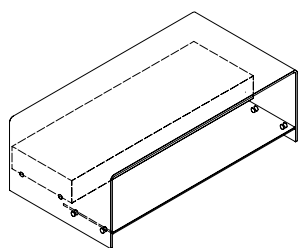

DIMENSIONS cm	SP. / TH.	COD.	M ³	KG
125x68x42h	12	P4160 _ _ _	0,48	67

FINITURE TOP / TOP FINISHES

VETRO FLOAT CLEAR GLASS	VETRO EXTRACHIARO EXTRALIGHT GLASS
Clear TRTR	Extralight TETE
€	€
1300	1430

FINITURE CASSETTO / DRAWER FINISHES

Legno / Wood



WG BI NC



TRTR



TETE

BRIDGE - WITH DRAWER

design Studio Sovet
2013

Tavolino in vetro curvato trasparente o trasparente extrachiario. Cassettera in noce canaletto, nero, bianco poro aperto o wengé.

*Coffee table in clear or extralight bent glass.
White opened pores, wengé or canaletto walnut drawer.*

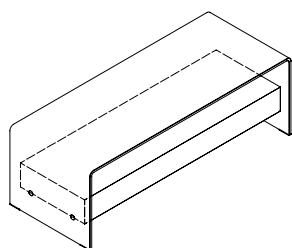
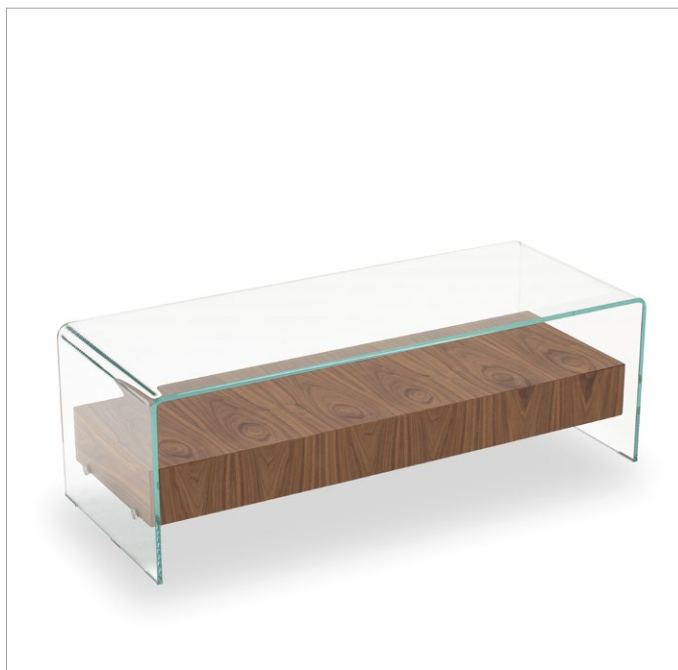

DIMENSIONS cm	SP. / TH.	COD.	M ³	KG
125x50x42h	12	P4150 _ _ _	0,36	50

FINITURE TOP / TOP FINISHES

VETRO FLOAT CLEAR GLASS	VETRO EXTRACHIARO EXTRALIGHT GLASS
Clear TRTR	Extralight TETE
€	€
1100	1200

FINITURE CASSETTO / DRAWER FINISHES

Legno / Wood



WG BI NC



TRTR



TETE

BRIDGE HALL

design Studio Sovet
1988

Console in vetro curvato trasparente, trasparente extrachiaro, placcato o laccato, mono o bicolore. Disponibile anche con ripiano in vetro.

Console in bent glass clear, extralight, plated or lacquered mono or two-tones. Available also with glass shelf.

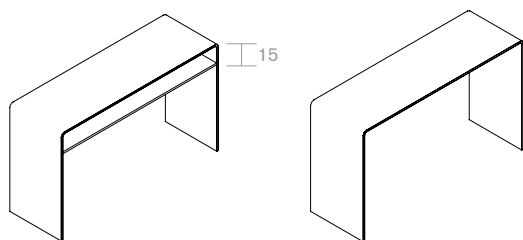

DIMENSIONS cm	SP. / TH.	COD.	M ³	KG
100x33x74h	12	P5130 _ _	0,33	31
100x33x74h <i>Con ripiano With shelf</i>	12	P5120 _ _	0,33	36
125x41x74h	12	P5133 _ _	0,48	41
125x41x74h <i>Con ripiano With shelf</i>	12	P5122 _ _	0,48	46

FINITURE TOP / TOP FINISHES

VETRO FLOAT CLEAR GLASS			VETRO EXTRACHIARO EXTRALIGHT GLASS			
Clear TRTR	Lacquered Cat. A	Two-tones Cat. A or C	Extralight TETE	Lacquered Cat. B	Two-tones Cat. B or D	Plated Cat. P
€	€	€	€	€	€	€
440	580	620	510	650	690	960
560	740	790	650	830	890	-
560	750	790	670	850	900	1240
650	890	960	790	1030	1100	-



TRTR



TETE

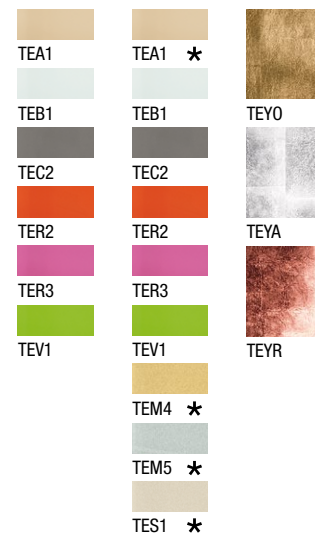

★ I colori contrassegnati possono essere utilizzati solo per il lato esterno e devono essere sempre protetti internamente da un secondo colore.

★ The marked colours can only be used on the external side and need to be protected by a second internal colour.

BRIDGE HALL - WITH DRAWER

design Studio Sovet
1988

Console in vetro curvato trasparente, trasparente extrachiaro o laccato, mono o bicolore. Cassettera in noce canaletto, bianco poro aperto o wengé.

Console in bent glass clear, extralight or lacquered mono or two-tones, various finishes. Canaletto walnut, white oak opened pores or wengé drawer.

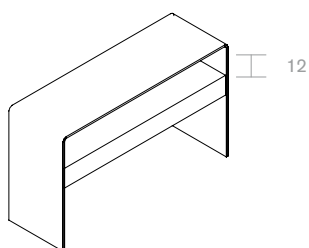

DIMENSIONS cm	SP. / TH.	COD.	M ³	KG
125x41x74h	12	P5101 _ _ _	0,48	61
125x41x86h	12	P5103 _ _ _	0,55	65

FINITURE TOP / TOP FINISHES

VETRO FLOAT CLEAR GLASS			VETRO EXTRACHIARO EXTRALIGHT GLASS		
Clear TRTR	Lacquered Cat. A	Two-tones Cat. A or C	Extralight TETE	Lacquered Cat. B	Two-tones Cat. B or D
€	€	€	€	€	€
1260	1450	1490	1370	1550	1600
1400	1580	1630	1490	1670	1720

FINITURE CASSETTO / DRAWER FINISHES

Legno / Wood



WG BI NC

TRTR	TETE
TRB2	TEA1
TRC1	TEA1 *
TRN1	TEB1
TRN2	TEB1
TRR1	TEC2
TRMP	TEC2
TRM1 *	TER2
TRM2 *	TER2
TRM3 *	TER3
	TER3
	TEV1
	TEV1
	TEM4 *
	TEM5 *
	TES1 *

* I colori contrassegnati possono essere utilizzati solo per il lato esterno e devono essere sempre protetti internamente da un secondo colore.

* The marked colours can only be used on the external side and need to be protected by a second internal colour.

CROSS - H.74

design Gianluigi Landoni
2014

Tavolo con struttura in metallo verniciato disponibile in varie finiture. Top in vetro temperato nelle versioni trasparente, trasparente extrachiaro, acidato o fumé. Nella versione cm 240x120 il top è stratificato 8+8 mm nelle finiture TFTF e TBTB.

Dining table with lacquered metal structure, various finishes. Tempered glass top available in clear, extralight, frosted or smoked finish. Laminated top 8+8 mm for the version cm 240x120 in the finishes TFTF and TBTB.

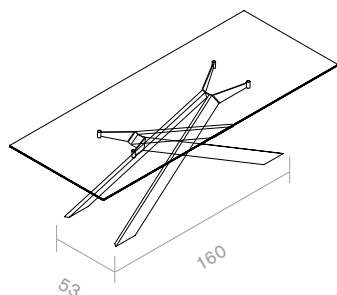

DIMENSIONS cm	TOP	BASE	GOD.	M ³	KG
240x106	12 FL	GB/GT/GC/GN/	P1460 _	0,46	130
	12 FL	BR	P1460 _	0,46	130
240x120		GB/GT/GC/GN	P1466 _	0,48	167
		BR	P1466 _	0,48	167
250x100	15 FL	GB/GT/GC/GN	P1462 _	0,45	147
	15 FL	BR	P1462 _	0,45	147

FINITURE BASE / BASE FINISHES

Metallo goffrato / Embossed metal



GB GT GC GN

Metallo brunito / Burnished metal



BR

★ Top in vetro stratificato mm 8 + 8

★ Top in laminated glass mm 8 + 8

FINITURE TOP / TOP FINISHES

VETRO FLOAT CLEAR GLASS	VETRO EXTRACHIARO EXTRALIGHT GLASS	ACIDATO FROSTED	FUME' SMOKED GLASS	FUME'/BRONZO SMOKED / BRONZED
Clear TRTR	Extralight TETE	Frosted AEAE	TFTF Sp. 12	Laminate 8+8 Sp. 16
€	€	€	€	€
-	-	-	2150	-
-	-	-	2650	-
2330	2650	2930	-	2450
2830	3150	3430	-	2950
2120	2390	2640	-	-
2620	2890	3140	-	-
 TRTR	 TETE	 AEAE	 TFTF	 TFTF ★ TBTB ★

CROSS - EXTENSIBLE H.76

design Gianluigi Landoni
2014

Tavolo con struttura in metallo verniciato disponibile in varie finiture. Top e allunghe in vetro spessore 12 mm temperato laccato in vari colori e finiture.

Dining table with lacquered metal structure, various finishes. Top and extensions in lacquered tempered glass, 12mm. thickness, various colours and finishes.

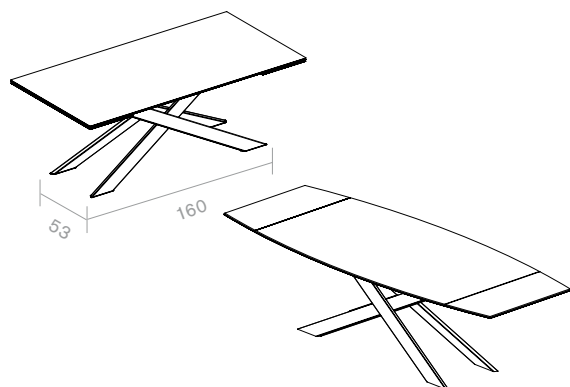

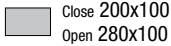
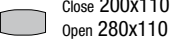
DIMENSIONS cm	TOP	BASE	COD.	M ³	KG	FINITURE TOP / TOP FINISHES			
						VETRO FLOAT CLEAR GLASS	VETRO EXTRACHIARO EXTRALIGHT GLASS		ACIDATO FROSTED
						Lacquered Cat. A / C	Lacquered Cat. B / D	Plated Cat. P	Lacquered Cat. E
						€	€	€	€
 Close 200x100 Open 280x100	12 FL45°	GB/GT/GC/GN	P1472_	0,61	181	3100	3290	3950	3430
		BR		0,61	181	3600	3790	4450	3930
 Close 200x110 Open 280x110	12 FL45°	GB/GT/GC/GN	P1477_	0,61	182	3220	3420	4120	3570
		BR		0,61	182	3720	3920	4620	4070

























FINITURE BASE / BASE FINISHES

Metallo goffrato / Embossed metal



Metallo brunito / Burnished metal



 TRB2	 TEA1	 TEYO	 AEA1
 TRC1	 TEB1	 TEYA	 AEB1
 TRN1	 TEC2	 TEYR	 AEC1
 TRN2	 TER2		 AEC2
 TRR1	 TER3		
 TRMP	 TEV1		
 TRM1	 TEM4		
 TRM2	 TEM5		
 TRM3	 TES1		

CROSS WOOD H.75

design Gianluigi Landoni
2014

Tavolo con struttura in metallo verniciato disponibile in varie finiture. Piano in multistrato di legno di betulla finlandese, spessore 26 mm, impiallacciato in varie essenze e finiture.

Dining table with lacquered metal structure, various finishes. Veneered multi-layer Finnish birch wood top, 26mm. thickness, various finishes.

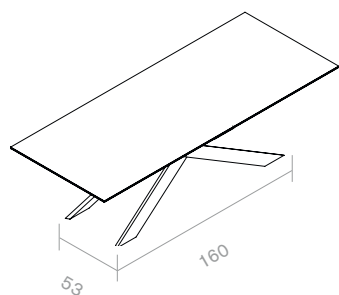

DIMENSIONS cm	SP. / TH. TOP	BASE	COD.	M ³	KG
240x110	26	GB/GT/GC/GN	P1464 _	0,46	95
240x110	26	BR	P1464 _	0,46	95
240x120	26	GB/GT/GC/GN	P1466 _	0,48	98
240x120	26	BR	P1466 _	0,48	98

FINITURE TOP / TOP FINISHES

LEGNO WOOD		
NOCE Canaletto Canaletto WALNUT	ROVERE OAK	ROVERE taglio sega saw cut OAK
€	€	€
2600	2600	2640
3100	3100	3140
2800	2800	2840
3300	3300	3340

FINITURE STRUTTURA / STRUCTURE FINISHES

Metallo laccato / Lacquered metal

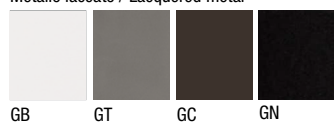

Metallo brunito / Burnished metal



NC



RN



R5



RG



R6



WG



R7

DOGE

design Guido Porcellato
2013

Tavolo con base in vetro extrachiaro trasparente e traversa di giunzione in legno, varie finiture, o in vetro extrachiaro trasparente. Top in vetro temperato extrachiaro trasparente o acidato. Disponibile anche nella versione laccata e placcata, vari colori e finiture.

Dining table with extralight glass base and crossbar available in wood, various finishes, or in extralight glass. Extralight clear or frosted tempered glass top. Available also in the lacquered or plated version, various colours and finishes.

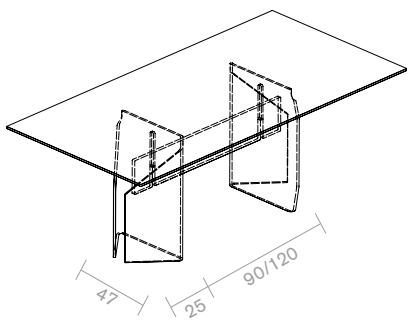

DIMENSIONS cm	SP. / TH.	COD.	M ³	KG
200x100x74h	Top 15 FL Temp.	P1020TETE _ _	0,41	120
250x100x74h	Top 15 FL Temp.	P1022TETE _ _	0,44	139



FINITURE TOP / TOP FINISHES

VETRO EXTRACHIAIRO EXTRALIGHT GLASS				ACIDATO FROSTED	
Extralight TETE	Lacquered Cat. B / D	Lacquered Cat. Z	Plated Cat. P	Frosted AEAE	Lacquered Cat. E
€	€	€	€	€	€
2220	2490	2490	3130	2420	2690
2470	2810	2810	3600	2720	3060

FINITURE BASE / BASE FINISHES

Vetro extrachiaro / Extralight glass



TETE

FINITURE TRAVERSA DI GIUNZIONE / CROSSBAR FINISHES

Vetro extrachiaro / Extralight glass



TETE

Legno / Wood

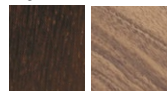

WG

NC



TETE



TEA1



TEB1



TEC2



TER2



TER3



TEV1



TEM4



TEM5



TES1



TEC1



TEN1



TEN2



TER1



TEM3



TEMP



TEYO



TEYA



TEYR



AEAE



AEA1



AEB1



AEC1



AEC2

FLÛTE BAR - H. 74

design Studio Sovet
2009

Tavolo con base in metallo cromato o laccato, varie finiture.
Top in HPL (sp. 12 mm - becco d'oca) o in vetro temperato,
trasparente o acidato, disponibile anche nella versione laccata,
vari colori.

Dining table with chromed or lacquered metal base, different finishes. Top available in HPL (th. 12 mm) or tempered glass, clear or frosted, available also in the lacquered version, various colours.

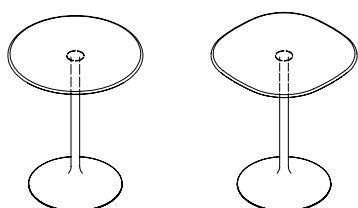

Ø 43



DIMENSIONS cm	TOP	BASE	COD.	M ³	KG	FINITURE TOP / TOP FINISHES					
						VETRO FLOAT CLEAR GLASS		VETRO EXTRACHIARO EXTRALIGHT GLASS		ACIDATO FROSTED	LAMINATO LAMINATE
						Clear TRTR	Lacquered Cat. A / C	Extralight TETE	Lacquered Cat. B / D	Cat. E / AEAE	Laminate Cat. HPL
						€	€	€	€	€	€
● Ø 62	10 BC	FB/FN	P1812 _ _ _	0,22	17	320	360	350	390	400	-
		LC	P1812LC _ _	0,22	17	360	400	390	430	440	-
■ 62x62	10 BC	FB/FN	P1822 _ _ _	0,22	17	320	360	350	390	400	460
		LC	P1822LC _ _	0,22	17	360	400	390	430	440	500
● Ø 80	10 BC	FB/FN	P1814 _ _ _	0,23	23	380	450	430	500	530	-
		LC	P1814LC _ _	0,23	23	420	490	470	540	570	-
■ 80x80	10 BC	FB/FN	P1824 _ _ _	0,23	24	380	450	430	500	530	560
		LC	P1824LC _ _	0,23	24	420	490	470	540	570	600

FINITURE BASE / BASE FINISHES

Cromo lucido / Polished chrome



LC

Metallo laccato / Lacquered metal



FB

FN



TRTR



TRC1



TRN1



TRN2



TRR1



TRMP



TRM1



TRM2



TRM3



TETE



TEA1



TEB1



TEC2



TER2



TER3



TEV1



TEM4



TEM5



TES1



AEA1



AEB1



AEC1



AEC2



AEAE



HB



HN

FLÛTE - ROUND / SHAPED H. 74

design Studio Sovet
2009

Tavolo con base in metallo cromato o laccato varie finiture. Top in HPL (sp. 12 mm - becco d'oca) o in vetro temperato, laccato o acidato laccato, vari colori.

Dining table with chromed or lacquered metal base, different finishes. Top available in HPL (th. 12 mm) or tempered glass, lacquered or frosted lacquered, various colours.

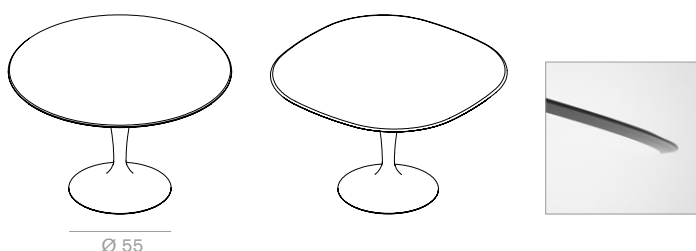

DIMENSIONS cm	TOP	BASE	COD.	M ³	KG
Ø 100	10 BC	FB/FC/FN/FT	P1648 _ _ _	0,45	37
		LC	P1648LC _ _	0,45	37
100x100	10 BC	FB/FC/FN/FT	P1646 _ _ _	0,45	38
		LC	P1646LC _ _	0,45	38
Ø 120	12 FL45°	FB/FC/FN/FT	P1650 _ _ _	0,48	53
		LC	P1650LC _ _	0,48	53
120x120	12 BC	FB/FC/FN/FT	P1644 _ _ _	0,48	55
		LC	P1644LC _ _	0,48	55

FINITURE TOP / TOP FINISHES

VETRO FLOAT CLEAR GLASS	VETRO EXTRACHIARO EXTRALIGHT GLASS	ACIDATO FROSTED	LAMINATO LAMINATE
Lacquered Cat. A / C	Lacquered Cat. B / D	Lacquered Cat. E	Laminato Cat. HPL
€	€	€	€
830	910	950	1000
880	960	1000	1050
830	910	950	1000
880	960	1000	1050
1060	1170	1250	-
1110	1220	1300	-
1070	1180	1260	-
1120	1230	1310	-

FINITURE BASE / BASE FINISHES

Cromo lucido / Polished chrome



LC

Metallo laccato / Lacquered metal



FB

FC

FN

FT

TRB2

TRC1

TRN1

TRN2

TRR1

TRMP

TRM1

TRM2

TRM3

TEA1

TEB1

TEC2

TER2

TER3

TEV1

TEM4

TEM5

TES1

AEA1

AEB1

AEC1

AEC2

HB

HN

HN

HN

HN

HN

FLÛTE - ROUND H. 74

design Studio Sovet
2009

Tavolo con base in metallo cromato o laccato, varie finiture.
Top in HPL (sp. 12 mm - becco d'oca) o in vetro temperato,
laccato o acidato laccato, vari colori.

Dining table with chromed or lacquered metal base, different finishes. Top available in HPL (th. 12 mm) or tempered glass, lacquered or frosted lacquered, various colours.

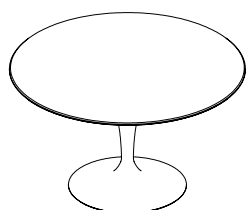

Ø 65



DIMENSIONS cm	TOP	BASE	GOD.	M ³	KG
Ø 130	12 FL45°	FB/FC/FN/FT	P1651 _ _ _	0,49	62
		LC	P1651LC _ _	0,49	62
Ø 140	12 FL45°	FB/FC/FN/FT	P1642 _ _ _	0,51	69
		LC	P1642LC _ _	0,51	69
Ø 150	12 FL45°	FB/FC/FN/FT	P1652 _ _ _	0,53	77
		LC	P1652LC _ _	0,53	77

FINITURE TOP / TOP FINISHES

VETRO FLOAT CLEAR GLASS	VETRO EXTRACHIARO EXTRALIGHT GLASS	ACIDATO FROSTED	LAMINATO LAMINATE
Lacquered Cat. A / C	Lacquered Cat. B / D	Lacquered Cat. E	Laminate Cat. HPL
€	€	€	€
1190	1320	1420	1160
1240	1370	1470	1210
1290	1440	1560	-
1340	1490	1610	-
1400	1570	1710	-
1450	1620	1760	-

FINITURE BASE / BASE FINISHES

Cromo lucido / Polished chrome



LC

Metallo laccato / Lacquered metal



FB

FC

FN

FT



TRB2



TRC1



TRN1



TRN2



TRR1



TRMP



TRM1



TRM2



TRM3



TEA1



TEB1



TEC2



TER2



TER3



TEV1



TEM4



TEM5



TES1



AEA1



AEB1



AEC1



AEC2



HB



HN

FLÛTE - ELLIPTICAL H. 74

design Studio Sovet
2009

Tavolo con base in metallo cromato o laccato, varie finiture.
Top in vetro temperato, laccato o acidato laccato, vari colori.

Dining table with chromed or lacquered metal base, different finishes. Top available in tempered glass, lacquered or frosted lacquered, various colours.



DIMENSIONS cm	TOP	BASE	COD.	M ³	KG
160x100	12 FL45°	FB/FC/FN/FT	P1653 _ _ _	0,49	59
		LC	P1653LC _ _	0,49	59
180x130	12 FL45°	FB/FC/FN/FT	P1654 _ _ _	0,54	80
		LC	P1654LC _ _	0,54	80
200x110	12 FL45°	FB/FC/FN/FT	P1655 _ _ _	0,53	76
		LC	P1655LC _ _	0,53	76

FINITURE TOP / TOP FINISHES

VETRO FLOAT CLEAR GLASS	VETRO EXTRACHIARO EXTRALIGHT GLASS	ACIDATO FROSTED
Lacquered Cat. A / C	Lacquered Cat. B / D	Lacquered Cat. E
€	€	€
1160	1280	1380
1210	1330	1430
1430	1610	1750
1480	1660	1800
1380	1550	1680
1430	1600	1730

FINITURE BASE / BASE FINISHES

Cromo lucido / Polished chrome



LC

Metallo laccato / Lacquered metal



FB

FC

FN

FT

TRB2
TRC1
TRN1
TRN2
TRR1
TRMP
TRM1
TRM2
TRM3

TEA1
TEB1
TEC2
TER2
TER3
TEV1
TEM4
TEM5
TES1

AEA1
AEB1
AEC1
AEC2

FLÛTE WOOD - ROUND H. 74

design Studio Sovet
2009

Tavolo con base in metallo cromato o laccato, varie finiture. Piano in multistrato di legno di betulla finlandese spessore 26 mm, con bordo a vista tagliato a 45°, impiallacciato noce oppure rovere sia in finitura spazzolata che taglio a sega.

Dining table with polished chrome or lacquered metal base, various finishes. Multi-layer Finnish birch wood top 26mm. thickness, 45°-cut edge, walnut or oak veneered, brushed or saw cut finish.

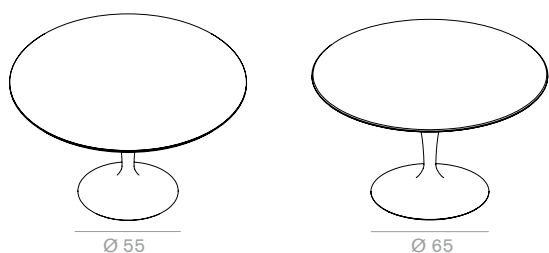

DIMENSIONS cm	TOP	BASE	COD.	M ³	KG	FINITURE TOP / TOP FINISHES		
						NOCE Canaletto Canaletto WALNUT	ROVERE OAK	ROVERE taglio sega saw cut OAK
						€	€	€
Ø 90	26	Ø 55 FB/FC/FN/FT	P1639 _ _	0,44	25	870	870	880
		Ø 55 LC	P1639LC _	0,44	25	920	920	930
Ø 130	26	Ø 65 FB/FC/FN/FT	P1651 _ _	0,49	35	1440	1440	1470
		Ø 65 LC	P1651LC _	0,49	35	1490	1490	1520
Ø 150	26	Ø 65 FB/FC/FN/FT	P1652 _ _	0,53	41	1770	1770	1810
		Ø 65 LC	P1652LC _	0,53	41	1820	1820	1860

FINITURE BASE / BASE FINISHES

Cromo lucido / Polished chrome



LC

Metallo laccato / Lacquered metal



FB FC FN FT



NC



RN



R5



RG



R6



WG



R7

FLÛTE - H. 37

design Studio Sovet
2011

Tavolino con base in metallo cromato o laccato, varie finiture. Top in HPL (sp. 12 mm - becco d'oca) o in vetro temperato, trasparente, acidato o decorato. Disponibile anche nella versione laccata, vari colori e finiture.

Coffee table with polished chrome or lacquered metal base, various finishes. Top available in HPL (th. 12 mm) or in tempered glass, clear, frosted or decorated. Available also in the lacquered version, various colours and finishes.

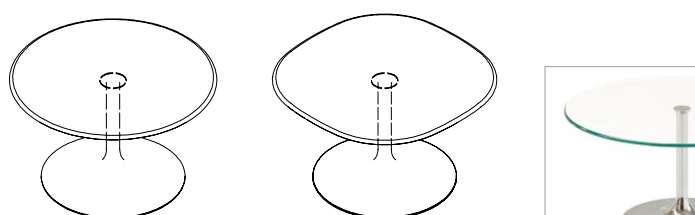

Ø 43

DIMENSIONS cm	TOP	BASE	COD.	M ³	KG	FINITURE TOP / TOP FINISHES					
						Clear TRTR	Lacquered Cat. A / C	Extralight TETE	Lacquered Cat. B / D	ACIDATO FROSTED Cat. E / AEAE	LAMINATO LAMINATE Lamine Cat. HPL
						€	€	€	€	€	€
● Ø 62	10 BC	FB/FN	P4750 _ _ _	0,13	16	280	320	310	350	360	-
		LC	P4750LC _ _	0,13	16	310	350	340	380	390	-
■ 62x62	10 BC	FB/FN	P4752 _ _ _	0,13	17	280	320	310	350	360	420
		LC	P4752LC _ _	0,13	17	310	350	340	380	390	450
● Ø 80	10 BC	FB/FN	P4754 _ _ _	0,14	22	340	410	390	460	490	-
		LC	P4754LC _ _	0,14	22	370	440	420	490	520	-
■ 80x80	10 BC	FB/FN	P4756 _ _ _	0,14	23	340	410	390	460	490	520
		LC	P4756LC _ _	0,14	23	370	440	420	490	520	550

FINITURE BASE / BASE FINISHES

Cromo lucido / Polished chrome



LC

Metallo laccato / Lacquered metal

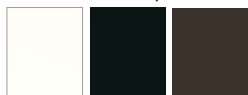

FB

FN

FC



TRTR



TRB2

TRC1

TRN1

TRN2

TRR1

TRMP

TRM1

TRM2

TRM3



TETE



TEA1

TEB1

TEC2

TER2

TER3

TEV1

TEM4

TEM5

TES1



AEA1

AEB1

AEC1

AEC2

AEAE



HB



HN

FLÛTE - H. 47

design Studio Sovet
2011

Tavolino con base in metallo cromato o laccato, varie finiture. Top in HPL (sp. 12 mm - becco d'oca) o in vetro temperato, trasparente, acidato o decorato. Disponibile anche nella versione laccata, vari colori e finiture.

Coffee table with polished chrome or lacquered metal base, various finishes. Top available in HPL (th. 12 mm) or in tempered glass, clear, frosted or decorated. Available also in the lacquered version, various colours and finishes.

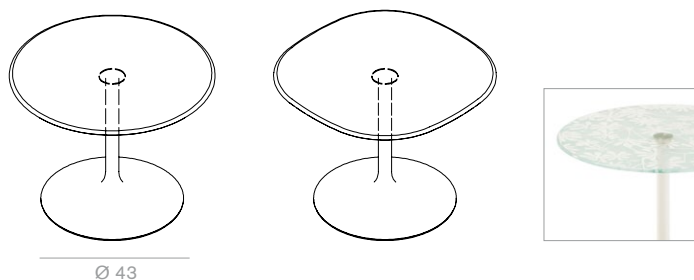

						FINITURE TOP / TOP FINISHES					
						VETRO FLOAT CLEAR GLASS		VETRO EXTRACHIARO EXTRALIGHT GLASS		ACIDATO FROSTED	LAMINATO LAMINATE
						Clear TRTR	Lacquered Cat. A / C	Extralight TETE	Lacquered Cat. B / D	Cat. E / AEAE	Laminate Cat. HPL
						€	€	€	€	€	€
DIMENSIONS cm	TOP	BASE	COD.	M ³	KG	290	330	320	360	370	-
						320	360	350	390	400	-
Ø 62	10 BC	FB/FN	P4770 _ _ _	0,15	17	290	330	320	360	370	-
		LC	P4770LC _ _	0,15	17	320	360	350	390	400	-
62x62	10 BC	FB/FN	P4772 _ _ _	0,15	17	290	330	320	360	370	430
		LC	P4772LC _ _	0,15	17	320	360	350	390	400	460
Ø 80	10 BC	FB/FN	P4774 _ _ _	0,17	23	350	420	400	470	500	-
		LC	P4774LC _ _	0,17	23	380	450	430	500	530	-
80x80	10 BC	FB/FN	P4776 _ _ _	0,17	23	350	420	400	470	500	530
		LC	P4776LC _ _	0,17	23	380	450	430	500	530	560

FINITURE BASE / BASE FINISHES

Cromo lucido / Polished chrome



LC

Metallo laccato / Lacquered metal

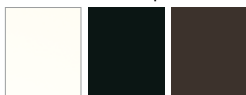

FB

FN

FC



TRTR



TRB2

TRC1

TRN1

TRN2

TRR1

TRMP

TRM1

TRM2

TRM3



TETE



TEA1

TEB1

TEC2

TER2

TER3

TEV1

TEM4

TEM5

TES1



AEA1

AEB1

AEC1

AEC2

AEAE



HB



HN

FLÛTE WOOD-CIRCLES - ROUND H.37-47

design Studio Sovet
2011

Tavolino con base in metallo cromato o laccato, varie finiture.
Disponibile nelle versioni con piano in multistrato di legno di betulla finlandese spessore 26 mm o in vetro temperato stampato Circles, spessore 8 mm.



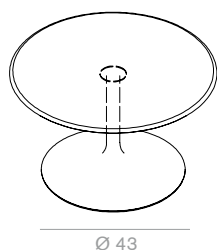





Coffee table with polished chrome or lacquered metal base, various finishes. Multi-layer Finnish birch wood top 26mm. thickness or Circles moulded tempered glass top, 8mm. thickness.



DIMENSIONS cm	TOP	BASE	COD.	M ³
Ø 62x37h	26 / 8	FB/FN/FC	P4750 _ _ _	0,13
		LC	P4750LC _ _	0,13
Ø 62x47h	26 / 8	FB/FN/FC	P4770 _ _ _	0,15
		LC	P4770LC _ _	0,15
Ø 90x37h	26 / 8	FB/FN/FC	P4757 _ _ _	0,15
		LC	P4757LC _ _	0,15
Ø 90x47h	26 / 8	FB/FN/FC	P4775 _ _ _	0,18
		LC	P4775LC _ _	0,18

FINITURE TOP / TOP FINISHES

	LEGNO WOOD			CIRCLES CIRCLES
	NOCE Canaletto Canaletto WALNUT	ROVERE OAK	ROVERE taglio sega saw cut OAK	Circles Cat. O
	€	€	€	€
	450	450	460	400
	480	480	490	430
	460	460	470	410
	490	490	500	440
	610	610	620	640
	640	640	650	670
	620	620	630	650
	650	650	660	680

FINITURE BASE / BASE FINISHES				
<p>Cromo lucido / Polished chrome</p>  <p>LC</p>	 <p>NC</p>	 <p>RN</p>	 <p>R5</p>	 <p>O1M3</p>
<p>Metallo laccato / Lacquered metal</p>    <p>FB FN FC</p>		 <p>RG</p>	 <p>R6</p>	 <p>O1S1</p>
		 <p>WG</p>	 <p>R7</p>	

FROG - H. 74

design Lievore Altherr Molina
2002

Tavolo in vetro curvo trasparente, trasparente extrachiaro o laccato mono o bicolore, vari colori. Disponibile anche nella versione placcata.

Dining table in clear, extralight or lacquered mono or two-tones bent glass, various colours. Available also in the plated version.

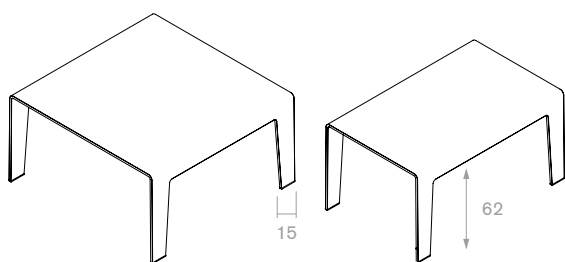

DIMENSIONS cm	SP. / TH.	COD.	M ³	KG
130x130	19	P1520 _ _	1,67	146
140x140	19	P1522 _ _	1,93	163
144x90	19	P1524 _ _	1,29	122

FINITURE TOP / TOP FINISHES

VETRO FLOAT CLEAR GLASS			VETRO EXTRACHIARO EXTRALIGHT GLASS			
Clear TRTR	Lacquered Cat. A	Two-tones Cat. A or C	Extralight TETE	Lacquered Cat. B	Two-tones Cat. B or D	Plated Cat. P
€	€	€	€	€	€	€
2170	2880	3040	2800	3520	3680	4710
2370	3170	3350	3080	3880	4060	5210
2000	2680	2830	2600	3280	3430	4400



TRTR

TRB2

TRC1

TRN1

TRN2

TRR1

TRMP

TRB2

TRC1

TRN1

TRN2

TRR1

TRMP

TRM1 *

TRM2 *

TRM3 *



TETE

TEA1

TEB1

TEC2

TER2

TER3

TEV1

TEA1 *

TEB1

TEC2

TER2

TER3

TEV1

TEM4 *

TEM5 *

TES1 *



TEYO

TEYA

TEYR

* I colori contrassegnati possono essere utilizzati solo per il lato esterno e devono essere sempre protetti internamente da un secondo colore.

* The marked colours can only be used on the external side and need to be protected by a second internal colour.

FROG - H. 34

design Lievore Altherr Molina
2002

Tavolino in vetro curvo trasparente, trasparente extrachiaro, placcato o laccato mono o bicolore.

Clear, extralight, plated or lacquered mono or two-tones, bent glass coffee table.

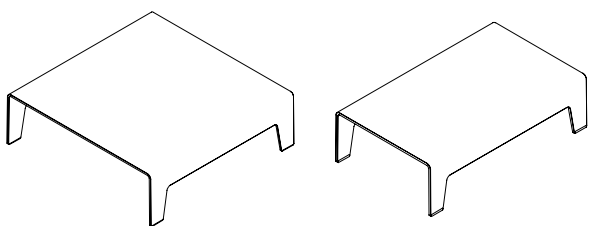

FINITURE TOP / TOP FINISHES

DIMENSIONS cm	SP. / TH.	COD.	M ³	KG	VETRO FLOAT CLEAR GLASS			VETRO EXTRACHIARO EXTRALIGHT GLASS			
					Clear TRTR	Lacquered Cat. A	Two-tones Cat. A or C	Extralight TETE	Lacquered Cat. B	Two-tones Cat. B or D	Plated Cat. P
					€	€	€	€	€	€	€
110x60x34h	12	P4420 _ _	0,29	36	560	770	820	670	880	930	1400
120x72x34h	12	P4422 _ _	0,40	43	630	880	940	760	1000	1070	1620
120x72x34h	15	P4425 _ _	0,43	49	820	1110	1180	-	-	-	-
140x72x34h	12	P4426 _ _	0,43	50	720	1010	1080	880	1170	1240	1890
140x72x34h	15	P4428 _ _	0,49	60	950	1280	1370	-	-	-	-
110x110x34h	12	P4430 _ _	0,54	58	770	1060	1140	1050	1340	1420	2080
130x130x34h	15	P4437 _ _	0,88	97	1090	1540	1650	1360	1810	1920	2700



TRTR

TRB2

TRC1

TRN1

TRN2

TRR1

TRMP

TRB2

TRC1

TRN1

TRN2

TRR1

TRMP

TRM1 *

TRM2 *

TRM3 *



TETE

TEA1

TEB1

TEC2

TER2

TER3

TEV1

TEA1 *

TEB1

TEC2

TER2

TER3

TEV1

TEM4 *

TEM5 *

TES1 *



TEYO



TEVA



TEYR

* I colori contrassegnati possono essere utilizzati solo per il lato esterno e devono essere sempre protetti internamente da un secondo colore.

* The marked colours can only be used on the external side and need to be protected by a second internal colour.

JEAN - RECTANGULAR H. 74

design Studio Sovet
1998

Tavolo con gambe in alluminio anodizzato, laccato o impiallacciato, varie finiture. Top in vetro temperato trasparente o acidato. Disponibile anche nella versione laccata, vari colori.

Dining table with legs in anodized aluminium, lacquered or wood veneered, various finishes. Tempered top in clear or frosted glass. Available also in the lacquered version, various colours.

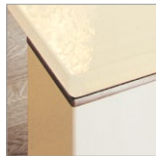
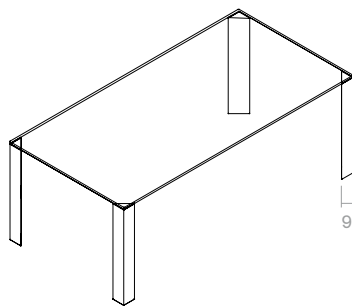

DIMENSIONS cm	TOP	BASE	COD.	M ³	KG
140x80	12 FL	OA/FC/FB/FN/FV	P1620 _ _ _	0,10	48
		/CL/NO	P1620 _ _ _	0,10	48
160x90	12 FL	OA/FC/FB/FN/FV	P1622 _ _ _	0,12	59
		/CL/NO	P1622 _ _ _	0,12	59
180x90	12 FL	OA/FC/FB/FN/FV	P1624 _ _ _	0,13	65
		/CL/NO	P1624 _ _ _	0,13	65
200x100 *	15 FL	OA/FC/FB/FN/FV	P1626 _ _ _	0,15	93
		/CL/NO	P1626 _ _ _	0,15	93

FINITURE TOP / TOP FINISHES

VETRO FLOAT CLEAR GLASS		ACIDATO FROSTED			
Clear TRTR	Lacquered Cat. A / C	Glass TETE/TFTF	Lacquered Cat. B / D	Frosted AEAE	Lacquered Cat. E
€	€	€	€	€	€
810	860	890	940	960	1010
980	1030	1060	1110	1130	1180
880	970	990	1080	1080	1170
1050	1140	1160	1250	1250	1340
940	1050	1060	1170	1160	1270
1110	1220	1230	1340	1330	1440
1200	1380	1410	1600	1610	1800
1370	1550	1580	1770	1780	1970

FINITURE BASE / BASE FINISHES

Alluminio anodizzato / Anodized aluminium



OA

Alluminio laccato / Lacquered aluminium



FB

FC

FN

FV

Legno / Wood



CL

NO

* Top in vetro stratificato 8mm + 8mm.

* Top in laminated glass 8mm + 8mm



TRTR



TRB2



TRC1



TRN1



TRN2



TRR1



TRMP



TRM1



TRM2



TRM3



TETE



TETF



TEA1



TEB1



TEC2



TER2



TER3



TEV1



TEM4



TEM5



TES1



AEAE



AEA1



AEB1



AEC1



AEC2

JEAN - SQUARE H. 74

design Studio Sovet
1998

Tavolo con gambe in alluminio anodizzato, laccato o impiallacciato, varie finiture. Top in vetro temperato trasparente o acidato. Disponibile anche nella versione laccata, vari colori.

Dining table with legs in anodized aluminium, lacquered or wood veneered, various finishes. Tempered top in clear or frosted glass. Available also in the lacquered version, various colours.

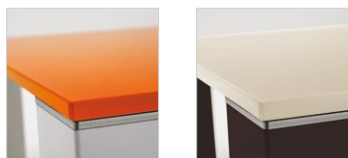
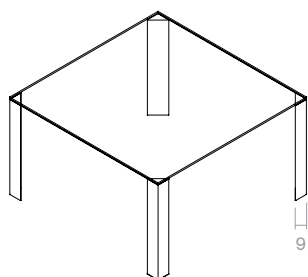

DIMENSIONS cm	TOP	BASE	COD.	M ³	KG
90x90	12 FL	OA/FC/FB/FN/FV	P1630 _ _ _	0,08	38
		/CL/NO	P1630 _ _ _	0,08	38
110x110	12 FL	OA/FC/FB/FN/FV	P1632 _ _ _	0,10	51
		/CL/NO	P1632 _ _ _	0,10	51
130x130	12 FL	OA/FC/FB/FN/FV	P1634 _ _ _	0,13	68
		/CL/NO	P1634 _ _ _	0,13	68
150x150	12 FL	OA/FC/FB/FN/FV	P1636 _ _ _	0,17	104
		/CL/NO	P1636 _ _ _	0,17	104



FINITURE TOP / TOP FINISHES

VETRO FLOAT CLEAR GLASS		ACIDATO FROSTED			
Clear TRTR	Lacquered Cat. A / C	Glass TETE/TFTF	Lacquered Cat. B / D	Frosted AEAE	Lacquered Cat. E
€	€	€	€	€	€
730	750	800	810	850	860
900	920	970	980	1020	1030
830	890	920	990	1000	1060
1000	1060	1090	1160	1170	1230
950	1070	1080	1200	1180	1300
1120	1240	1250	1370	1350	1470
1270	1580	1520	1820	1740	2050
1440	1750	1690	1990	1910	2220

FINITURE BASE / BASE FINISHES

Alluminio anodizzato / Anodized aluminium



OA

Alluminio laccato / Lacquered aluminium



FB

FC

FN

FV

Legno / Wood



CL

NO



TRTR



TRB2

TRC1

TRN1

TRN2

TRR1

TRMP

TRM1

TRM2

TRM3



TETE

TETF



TEA1

TEB1

TEC2

TER2

TER3

TEV1

TEM4

TEM5

TES1



AEAE



AEA1

AEB1

AEC1

AEC2

JEAN - H. 24

design Studio Sovet
1998

Tavolino con gambe in alluminio anodizzato, laccato o impiallacciato, varie finiture. Top in vetro temperato trasparente o acidato. Disponibile anche nella versione laccata, vari colori.

Coffee table with legs in anodized aluminium, lacquered or wood veneered, various finishes. Tempered glass top in clear or frosted glass. Available also in the lacquered version, various colours.

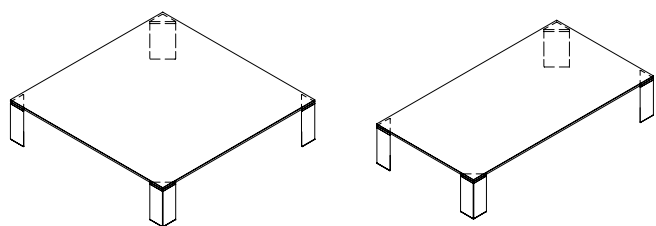

DIMENSIONS cm	TOP	BASE	COD.	M ³	KG	FINITURE TOP / TOP FINISHES					
						VETRO FLOAT CLEAR GLASS		ACIDATO FROSTED			
						Clear TRTR	Lacquered Cat. A / C	Glass TETE/TFTF	Lacquered Cat. B / D	Frosted AEAE	Lacquered Cat. E
						€	€	€	€	€	€
110x60x24h	12 FL Temp.	OA/FC/FB/FN/FV	P4580 _ _ _	0,06	26	560	560	610	610	650	650
		WG/CL/NO	P4580 _ _ _	0,06	26	620	620	670	670	710	710
130x70x24h	12 FL Temp.	OA/FC/FB/FN/FV	P4584 _ _ _	0,07	35	620	640	690	710	740	770
		WG/CL/NO	P4584 _ _ _	0,07	35	680	700	750	770	800	830
90x90x24h	12 FL Temp.	OA/FC/FB/FN/FV	P4586 _ _ _	0,06	31	590	610	660	670	710	720
		WG/CL/NO	P4586 _ _ _	0,06	31	650	670	720	730	770	780
110x110x24h	12 FL Temp.	OA/FC/FB/FN/FV	P4588 _ _ _	0,09	45	690	750	780	850	860	920
		WG/CL/NO	P4588 _ _ _	0,09	45	750	810	840	910	920	980

FINITURE BASE / BASE FINISHES

Alluminio anodizzato / Anodized aluminium



OA

Alluminio laccato / Lacquered aluminium



FB

FC

FN

FV

Legno / Wood



WG

CL

NO



TRTR



TRB2



TRC1



TRN1



TRN2



TRR1



TRMP



TRM1



TRM2



TRM3



TETE



TFTF



TEA1



TEB1



TEC2



TER2



TER3



TEV1



TEM4



TEM5



TES1



AEAE



AEA1



AEB1



AEC1



AEC2

JEAN - H. 39

design Studio Sovet
1998

Tavolino con gambe in alluminio anodizzato, laccato o impiallacciato, varie finiture. Top in vetro temperato trasparente o acidato. Disponibile anche nella versione laccata, vari colori.

Coffee table with legs in anodized aluminium, lacquered or wood veneered, various finishes. Tempered glass top in clear or frosted glass. Available also in the lacquered version, various colours.

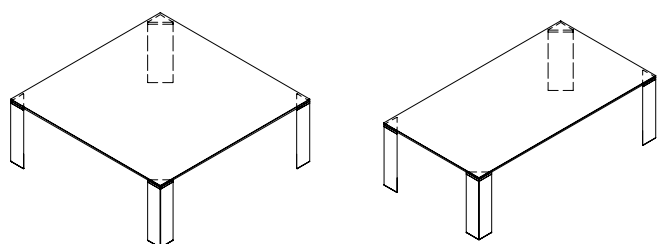

DIMENSIONS cm	TOP	BASE	COD.	M ³	KG
110x60x39h	12 FL Temp.	OA/FC/FB/FN/FV	P4581 _ _ _	0,06	28
		WG/CL/NO	P4581 _ _ _	0,06	28
130x70x39h	12 FL Temp.	OA/FC/FB/FN/FV	P4585 _ _ _	0,08	37
		WG/CL/NO	P4585 _ _ _	0,08	37
90x90x39h	12 FL Temp.	OA/FC/FB/FN/FV	P4587 _ _ _	0,07	33
		WG/CL/NO	P4587 _ _ _	0,07	33
110x110x39h	12 FL Temp.	OA/FC/FB/FN/FV	P4589 _ _ _	0,09	47
		WG/CL/NO	P4589 _ _ _	0,09	47

FINITURE BASE / BASE FINISHES

Alluminio anodizzato / Anodized aluminium



OA

Alluminio laccato / Lacquered aluminium



FB

FC

FN

FV

Legno / Wood

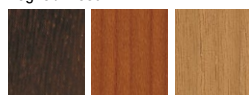

WG

CL

NO

FINITURE TOP / TOP FINISHES

VETRO FLOAT CLEAR GLASS		ACIDATO FROSTED			
Clear TRTR	Lacquered Cat. A / C	Glass TETE/TFTF	Lacquered Cat. B / D	Frosted AEAE	Lacquered Cat. E
€	€	€	€	€	€
600	600	650	650	690	690
700	700	750	750	790	790
660	680	730	750	780	810
760	780	830	850	880	910
630	650	700	710	750	760
730	750	800	810	850	860
730	790	820	890	900	960
830	890	920	990	1000	1060



TRTR



TRB2

TRC1

TRN1

TRN2

TRR1

TRMP

TRM1

TRM2

TRM3



TETE

TFTF



TEA1

TEB1

TEC2

TER2

TER3

TEV1

TEM4

TEM5

TES1



AEAE



AEA1

AEB1

AEC1

AEC2

JEAN - H. 48

design Studio Sovet
1998

Tavolino con gambe in alluminio anodizzato, laccato o impiallacciato, varie finiture. Top in vetro temperato trasparente o acidato. Disponibile anche nella versione laccata, vari colori.

Coffee table with legs in anodized aluminium, lacquered or wood veneered, various finishes. Tempered glass top in clear or frosted glass. Available also in the lacquered version, various colours.

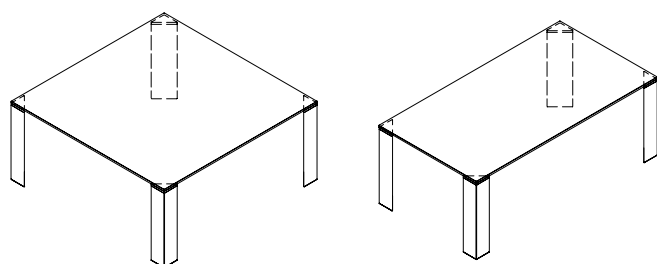

DIMENSIONS cm	TOP	BASE	COD.	M ³	KG	FINITURE TOP / TOP FINISHES					
						VETRO FLOAT CLEAR GLASS		ACIDATO FROSTED			
						Clear TRTR	Lacquered Cat. A / C	Glass TETE/TFTF	Lacquered Cat. B / D	Frosted AEAE	Lacquered Cat. E
						€	€	€	€	€	€
110x60x48h	12 FL Temp.	OA/FC/FB/FN/FV	P4582 _ _ _	0,06	29	620	620	670	670	710	710
		WG/CL/NO	P4582 _ _ _	0,06	29	760	760	810	810	850	850
130x70x48h	12 FL Temp.	OA/FC/FB/FN/FV	P4583 _ _ _	0,08	38	680	700	750	770	800	830
		WG/CL/NO	P4583 _ _ _	0,08	38	820	840	890	910	940	970
90x90x48h	12 FL Temp.	OA/FC/FB/FN/FV	P4990 _ _ _	0,07	34	650	670	720	730	770	780
		WG/CL/NO	P4990 _ _ _	0,07	34	790	810	860	870	910	920
110x110x48h	12 FL Temp.	OA/FC/FB/FN/FV	P4991 _ _ _	0,10	48	750	810	840	910	920	980
		WG/CL/NO	P4991 _ _ _	0,10	48	890	950	980	1050	1060	1120

FINITURE BASE / BASE FINISHES

Alluminio anodizzato / Anodized aluminium



OA

Alluminio laccato / Lacquered aluminium



FB

FC

FN

FV

Legno / Wood

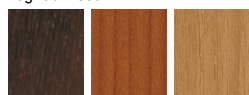

WG

CL

NO



TRTR



TRB2



TRC1



TRN1



TRN2



TRR1



TRMP



TRM1



TRM2



TRM3



TETE



TETF



TEA1



TEB1



TEC2



TER2



TER3



TEV1



TEM4



TEM5



TES1



AEAE



AEA1



AEB1



AEC1



AEC2

LAMBDA - ROUND H. 76

design Gianluigi Landoni
2011

Tavolo con base in cristalplant bianco opaco o in legno di frassino con finitura tinto rovere, wengè, noce canaletto o in legno massello noce canaletto. Top in vetro temperato trasparente, trasparente extrachiario o fumé.

Dining table with mat white cristalplant base or in ash wood, oak, wengé, canaletto walnut stained or in solid wood canaletto walnut. Clear, extralight or smoked tempered glass top.

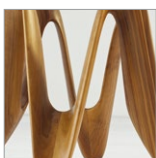
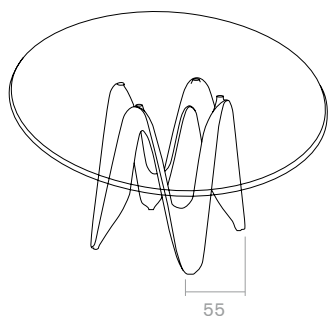

DIMENSIONS cm	TOP	BASE	COD.	M ³	KG
● Ø 140	12 FL45°	CB	P1041CB __	0,48	100
		RF/WF	P1041 __ __	0,48	66
		NC	P1041NC __	0,48	66
● Ø 150	12 FL45°	CB	P1042CB __	0,50	108
		RF/WF	P1042 __	0,50	74
		NC	P1042NC __	0,50	74
● Ø 170	12 FL45°	CB	P1044CB __	0,54	126
		RF/WF	P1044 __	0,54	92
		NC	P1044NC __	0,54	92

FINITURE BASE / BASE FINISHES

Cristalplant



CB

Legno frassino tinto / Stained ash wood



RF

WF

Legno noce massello / Solid wood walnut



NC



FINITURE TOP / TOP FINISHES

VETRO FLOAT CLEAR GLASS	VETRO EXTRACHIARIO /VETRO FUMÉ EXTRALIGHT GLASS / SMOKED GLASS
Clear TRTR	Extralight/Smoked TETE/TFTF
€	€
2200	2350
2980	3130
3280	3430
2270	2440
3050	3220
3350	3520
2430	2650
3210	3430
3510	3730



TRTR



TETE



TFTF

LAMBDA - ELLIPTICAL H. 76

design Gianluigi Landoni
2011

Tavolo con base in cristalplant bianco opaco o in legno di frassino con finitura tinto rovere, wengè, noce canaletto o in legno massello noce canaletto. Top in vetro temperato trasparente, trasparente extrachiaro o fumé.

Dining table with mat white cristalplant base or in ash wood, oak, wengé, canaletto walnut stained or in solid wood canaletto walnut. Clear, extralight or smoked tempered glass top.

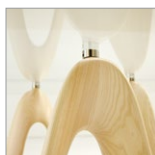
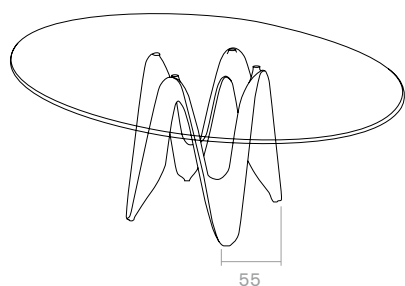

DIMENSIONS cm	TOP	BASE	COD.	M ³	KG
180x130	12 FL45°	CB	P1046CB __	0,50	111
		RF/WF	P1046 __	0,50	77
		NC	P1046NC __	0,50	77
200x110	12 FL45°	CB	P1048CB __	0,49	107
		RF/WF	P1048 __	0,49	73
		NC	P1048NC __	0,49	73
220x130	12 FL45°	CB	P1049CB __	0,53	125
		RF/WF	P1049 __	0,53	91
		NC	P1049NC __	0,53	91

FINITURE TOP / TOP FINISHES

VETRO FLOAT CLEAR GLASS	VETRO EXTRACHIARO /VETRO FUMÉ EXTRALIGHT GLASS / SMOKED GLASS
Clear TRTR	Extralight/Smoked TETE/TFTF
€	€
2290	2470
3070	3250
3370	3550
2260	2430
3040	3210
3340	3510
2430	2650
3210	3430
3510	3730

FINITURE BASE / BASE FINISHES

Cristalplant



CB

Legno frassino tinto / Stained ash wood



RF

WF

Legno noce massello / Solid wood walnut



NC



TRTR



TETE



TFTF

LAMBDA - SQUARE / RECTANGULAR H. 76

design Gianluigi Landoni
2011

Tavolo con base in cristalplant bianco opaco o in legno di frassino con finitura tinto rovere, wengè, noce canaletto o in legno massello noce canaletto. Top in vetro temperato trasparente o trasparente extrachiaro.

Dining table with mat white cristalplant base or in ash wood, oak, wengè, canaletto walnut stained or in solid wood canaletto walnut. Clear or extralight tempered glass top.

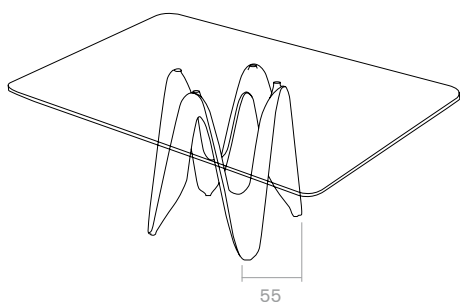
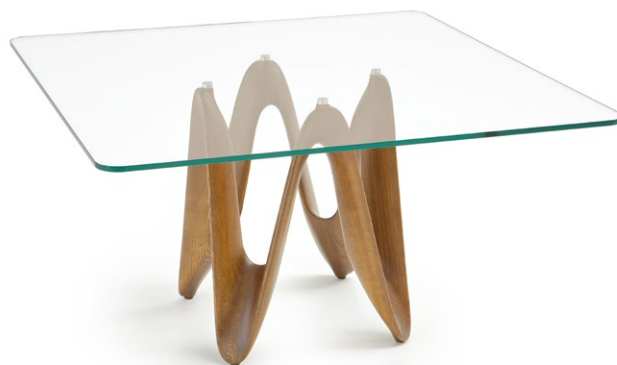

DIMENSIONS cm	TOP	BASE	COD.	M ³	KG
140x140	15 FL	CB	P1050CB __	0,48	128
		RF/WF	P1050 __	0,48	94
		NC	P1050NC __	0,48	94
200x120	15 FL	CB	P1057CB __	0,51	146
		RF/WF	P1057 __	0,51	112
		NC	P1057NC __	0,51	112
220x120	15 FL	CB	P1058CB __	0,52	156
		RF/WF	P1058 __	0,52	122
		NC	P1058NC __	0,52	122

FINITURE TOP / TOP FINISHES

VETRO FLOAT CLEAR GLASS	VETRO EXTRACHIARO EXTRALIGHT GLASS
Clear TRTR	Extralight TETE
€	€
2350	2560
3130	3340
3430	3640
2540	2800
3320	3580
3620	3880
2620	2910
3400	3690
3700	3990

FINITURE BASE / BASE FINISHES

Cristalplant



CB

Legno frassino tinto / Stained ash wood



RF

WF

Legno noce massello / Solid wood walnut



NC



TRTR



TETE

LAMBDA - TWO BASES H. 76

design Gianluigi Landoni
2011

Tavolo con basi in cristalplant bianco opaco o in legno di frassino con finitura tinto rovere, wengè, noce canaletto o in legno massello noce canaletto. Top in vetro temperato trasparente o trasparente extrachiaro.

Dining table with mat white cristalplant bases or in ash wood, oak, wengè, canaletto walnut stained or in solid wood canaletto walnut. Clear or extralight tempered glass top.

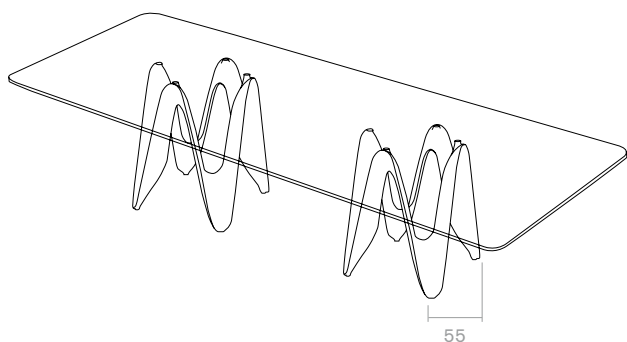

DIMENSIONS cm	TOP	BASE	COD.	M ³	KG
320x120	15 FL	CB	P1054CB __	0,94	252
		RF/WF	P1054 __	0,94	184
		NC	P1054NC __	0,94	184
320x120	8+8 *	CB	P1055CB __	0,94	261
		RF/WF	P1055 __	0,94	193
		NC	P1055NC __	0,94	193

FINITURE BASE / BASE FINISHES

Cristalplant



CB

Legno frassino tinto / Stained ash wood



RF

WF

Legno noce massello / Solid wood walnut





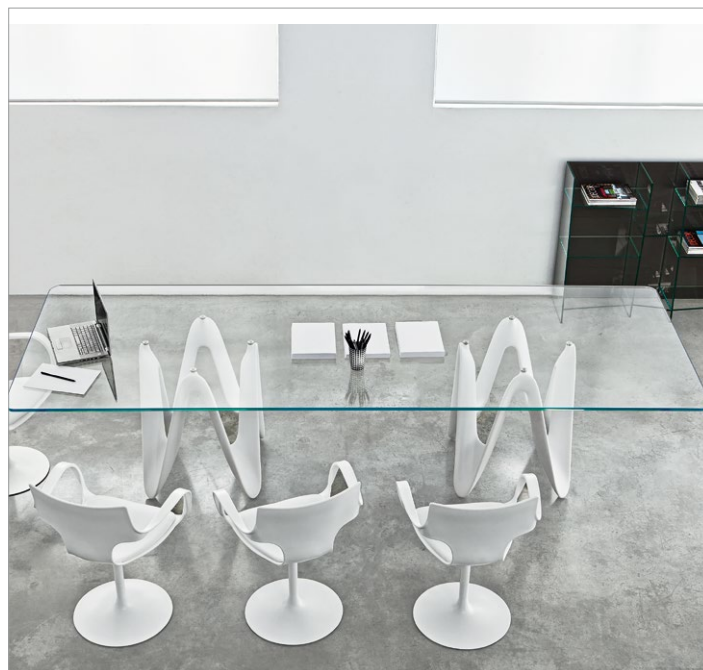

NC

* Top in vetro stratificato 8mm + 8mm

* Top in laminated glass 8mm + 8mm



FINITURE TOP / TOP FINISHES

VETRO FLOAT CLEAR GLASS	VETRO EXTRACHIARO EXTRALIGHT GLASS	FUMÉ / BRONZO SMOKED / BRONZED
Clear TRTR	Extralight TETE	Laminate 8+8 Sp. 16
€	€	
4650	5060	-
6150	6560	-
6450	6860	-
-	-	5060
-	-	6560
-	-	6860
		
TRTR	TETE	TFTF *
		
		TBTB *

PALACE - RECTANGULAR H. 74

design Lievore Altherr Molina
2002

Tavolo con base inox satinato o metallo laccato, varie finiture. Top in vetro temperato laccato, acidato laccato o placcato, vari colori. Disponibile anche con il top in rovere tinto wengé.

Dining table with base in mat stainless steel or in lacquered metal, various finishes. Lacquered, frosted lacquered or plated glass top, various colours. Available also with top in oak wood stained wengé.

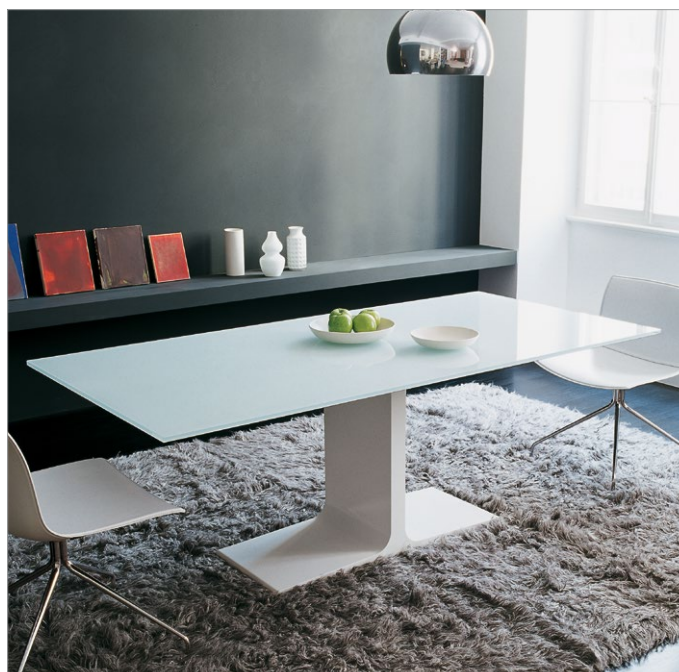
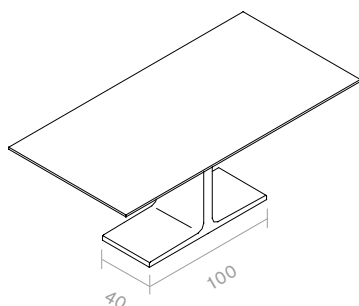

FINITURE TOP / TOP FINISHES

DIMENSIONS cm	TOP	BASE	COD.	M ³	KG	FINITURE TOP / TOP FINISHES			
						VETRO FLOAT CLEAR GLASS	VETRO EXTRACHIARO EXTRALIGHT GLASS		ACIDATO FROSTED
						Lacquered Cat. A / C	Lacquered Cat. B / D	Plated Cat. P	Lacquered Cat. E
						€	€	€	€
170x90	12 FL	FB/FC/FN/FT	P1560 _ _ _	0,47	111	1720	1840	2260	1930
		IX	P1560IX _ _	0,47	111	3070	3190	3610	3280
200x100	15 FL	FB/FC/FN/FT	P1564 _ _ _	0,50	142	2080	2300	2940	2500
		IX	P1564IX _ _	0,50	142	3430	3650	4290	3850
250x100	15 FL	FB/FC/FN/FT	P1566 _ _ _	0,59	191	2400	2670	3460	2920
		IX	P1566IX _ _	0,59	191	3750	4020	4810	4270
240x120	15 FL	FB/FC/FN/FT	P1559 _ _ _	0,56	174	2660	2970	3880	3260
		IX	P1559IX _ _	0,56	174	4010	4320	5230	4610

FINITURE BASE / BASE FINISHES

Acciaio Inox / Stainless steel



IX

Metallo laccato / Lacquered metal



FB

FC

FN

FT



TRB2



TRC1



TRN1



TRN2



TRR1



TRMP



TRM1



TRM2



TRM3



TEA1



TEB1



TEC2



TER2



TER3



TEV1



TEM4



TEM5



TES1



TEYO



TEYA



TEYR



AEA1



AEB1



AEC1



AEC2

PALACE - BARREL SHAPED / ELLIPTICAL H. 74

design Lievore Altherr Molina
2002

Tavolo con base inox satinato o metallo laccato, varie finiture.
Top in vetro temperato laccato, acidato laccato o placcato,
vari colori.

Dining table with base in mat stainless steel or in lacquered metal, various finishes. Lacquered, frosted lacquered or plated glass top, various colours.

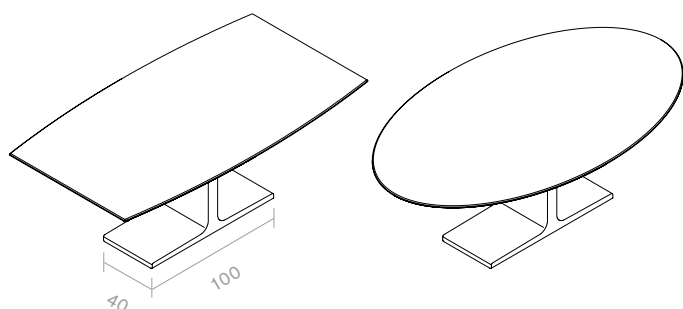

DIMENSIONS cm	TOP	BASE	GOD.	M ³	KG
200x110	12 FL45°	FB/FC/FN/FT	P1568 _ _ _	0,52	129
		IX	P1568IX _ _	0,52	129
200x110	12 FL45°	FB/FC/FN/FT	P1556 _ _ _	0,52	120
		IX	P1556IX _ _	0,52	120
220x130	12 FL45°	FB/FC/FN/FT	P1557 _ _ _	0,56	138
		IX	P1557IX _ _	0,56	138

FINITURE TOP / TOP FINISHES

VETRO FLOAT CLEAR GLASS	VETRO EXTRACHIARO EXTRALIGHT GLASS		ACIDATO FROSTED
	Lacquered Cat. A / C	Lacquered Cat. B / D	Plated Cat. P
€	€	€	€
2000	2170	2760	2300
3350	3520	4110	3650
2000	2170	2760	2300
3350	3520	4110	3650
2340	2560	3340	2730
3690	3910	4690	4080

FINITURE BASE / BASE FINISHES

Acciaio Inox / Stainless steel



IX

Metallo laccato / Lacquered metal



FB

FC

FN

FT



TRB2



TRC1



TRN1



TRN2



TRR1



TRMP



TRM1



TRM2



TRM3



TEA1



TEB1



TEC2



TER2



TER3



TEV1



TEM4



TEM5



TES1



TEYO



TEYA



TEYR



AEA1



AEB1



AEC1



AEC2

PALACE WOOD - RECTANGULAR H. 74

design Lievore Altherr Molina
2002

Tavolo con base inox satinato o metallo laccato, varie finiture. Piano in multistrato di legno di betulla finlandese spessore 26 mm, con bordo a vista tagliato a 45°, impiallacciato noce oppure rovere, finitura spazzolata o taglio sega.

Dining table with stainless steel or lacquered metal base, various finishes. Multi-layer Finnish birch wood top 26mm. thickness, 45°-cut edge, walnut or oak veneered, brushed or saw cut finish.

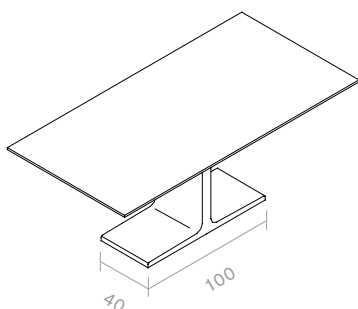

DIMENSIONS cm	TOP	BASE	COD.	M ³	KG
240x110	26	FB/FC/FN/FT	P1558 _ _	0,49	103
		IX	P1558IX _ _	0,49	103
240x120	26	FB/FC/FN/FT	P1559 _ _	0,51	105
		IX	P1559IX _ _	0,51	105

FINITURE BASE / BASE FINISHES

Acciaio Inox / Stainless steel



IX







Metallo laccato / Lacquered metal



FB FC FN FT

FINITURE TOP / TOP FINISHES

LEGNO WOOD		
NOCE Canaletto Canaletto WALNUT	ROVERE OAK	ROVERE taglio sega saw cut OAK
€	€	€
2660	2660	2700
4010	4010	4050
2860	2860	2900
4210	4210	4250

 NC	 RN	 R5
	 RG	 R6
	 WG	 R7





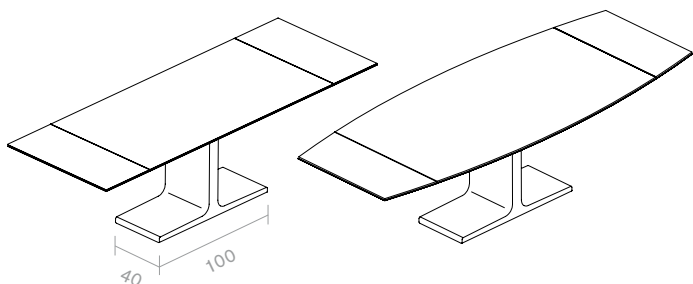

PALACE - EXTENSIBLE H. 74

design Studio Sovet
2010

Tavolo allungabile con base inox satinato o metallo laccato, varie finiture. Top allungabile in vetro laccato, acidato laccato o placcato. Struttura allungabile con finitura alluminio.

Extensible dining table with mat stainless steel or lacquered metal base, various finishes. Lacquered, frosted lacquered or plated extensible glass top. Extensible structure with aluminium finish.



DIMENSIONS cm	TOP	BASE	COD.	M ³	KG
 Close 170x90  Open 250x90	12 FL	FB/FC/FN/FT	P1572 _ _ _	0,63	164
		IX	P1572IX _ _	0,63	164
 Close 200x100  Open 280x100	12 FL	FB/FC/FN/FT	P1575 _ _ _	0,69	188
		IX	P1575IX _ _	0,69	188
 Close 200x110  Open 280x110	12 FL45°	FB/FC/FN/FT	P1577 _ _ _	0,70	187
		IX	P1577IX _ _	0,70	187

FINITURE TOP / TOP FINISHES

VETRO FLOAT CLEAR GLASS	VETRO EXTRACHIARO EXTRALIGHT GLASS		ACIDATO FROSTED
Lacquered Cat. A / C	Lacquered Cat. B / D	Plated Cat. P	Lacquered Cat. E
€	€	€	€
2970	3150	3770	3280
4320	4500	5120	4630
3340	3570	4340	3730
4690	4920	5690	5080
3460	3690	4490	3860
4810	5040	5840	5210

FINITURE BASE / BASE FINISHES

Acciaio Inox / Stainless steel



IX

Metallo laccato / Lacquered metal



FB

FC

FN

FT



TRB2



TRC1



TRN1



TRN2



TRR1



TRMP



TRM1



TRM2



TRM3



TEA1



TEB1



TEC2



TER2



TER3



TEV1



TEM4



TEM5



TES1



TEYO



TEYA



TEYR



AEA1



AEB1



AEC1



AEC2

PALACE - H. 39

design Lievore Altherr Molina
2002

Tavolino con base in metallo laccato, varie finiture.
Top rettangolare o sagomato in vetro temperato laccato,
acidato o placcato. Disponibile anche con top in legno.

Coffee table with base in lacquered metal, various finishes. Tempered rectangular or shaped top in lacquered, frosted or plated glass. Available also with wooden top.

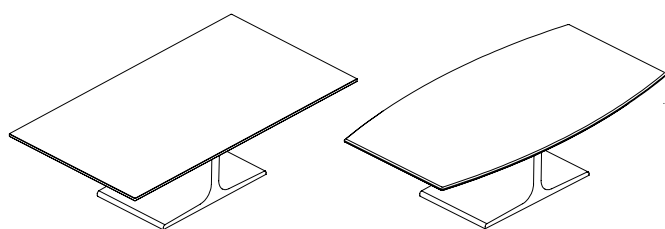

DIMENSIONS cm	TOP	BASE	COD.	M ³	KG
130x70x39h	12 FL Temp.	FB/FC/FN	P4590 _ _ _	0,18	49
130x70x39h	12 FL45° Temp.	FB/FC/FN	P4595 _ _ _	0,18	47

FINITURE TOP / TOP FINISHES

VETRO FLOAT CLEAR GLASS	VETRO EXTRACHIARO EXTRALIGHT GLASS		ACIDATO FROSTED	LEGNO WOOD
Lacquered Cat. A / C	Lacquered Cat. B / D	Plated Cat. P	Lacquered Cat. E	WG
€	€	€	€	€
970	1040	1290	1100	1000
950	1030	1280	1080	-

FINITURE BASE / BASE FINISHES				
<p>Metallo laccato / Lacquered metal</p> <p>FB FC FN</p>	<p>TRB2 TRC1 TRN1 TRN2 TRR1 TRMP TRM1 TRM2 TRM3</p>	<p>TEA1 TEB1 TEC2 TER2 TER3 TEV1 TEM4 TEM5 TES1</p>	<p>TEYO TEYA TEYR</p>	<p>AEA1 AEB1 AEC1 AEC2 WG</p>

PARTY / LIVE - BASE (TABLE H. 74)

design Studio Sovet
1988

Basi per tavoli a semicerchio o con forma a "S" in vetro curvo trasparente, trasparente extrachiaro o laccato, mono o bicolore.

Semicircle or "S-shape" bases for dining tables in clear, extralight or lacquered mono or two-tones glass.

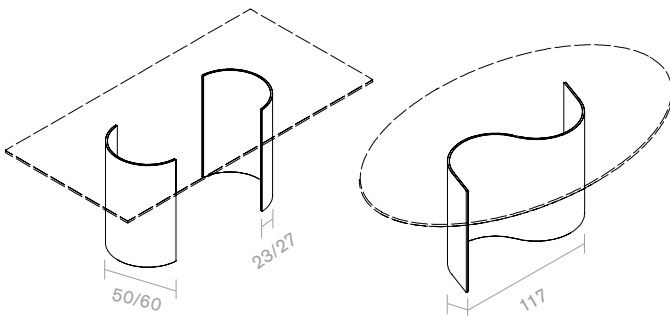

FINITURE BASE / BASE FINISHES

DIMENSIONS cm	SP. / TH.	COD.	M ³	KG	VETRO FLOAT CLEAR GLASS			VETRO EXTRACHIARO EXTRALIGHT GLASS		
					Clear TRTR	Lacquered Cat. A	Two-tones Cat. A or C	Extralight TETE	Lacquered Cat. B	Two-tones Cat. B or D
					€	€	€	€	€	€
Ø 50x72h	12 FL - Base only ①	PB050 _ _	0,17	35	450	630	680	530	710	760
Ø 60x72h	15 FL - Base only ②	PB060 _ _	0,25	53	670	910	970	820	1060	1120
117x38x72h	12 FL - Base only ③	PB080 _ _	0,42	42	550	750	800	640	840	890

TOP CONSIGLIATI / SUGGESTED TOP

- ① **BASE ART. PB050**
Vedi top abbinabili a pag. 34-35 /
Please see matching tops on page. 34-35
- ② **BASE ART. PB060**
Vedi top abbinabili a pag. 34-35 /
Please see matching tops on page. 34-35
- ③ **BASE ART. PB080**
Vedi top abbinabili a pag. 34-35 /
Please see matching tops on page. 34-35

TRTR	TRB2	TRB2	TETE	TEA1	TEA1 *
	TRC1	TRC1		TEB1	TEB1
	TRN1	TRN1		TEC2	TEC2
	TRN2	TRN2		TER2	TER2
	TRR1	TRR1		TER3	TER3
	TRMP	TRMP		TEV1	TEV1
		TRM1 *			TEM4 *
		TRM2 *			TEM5 *
		TRM3 *			TES1 *

* I colori contrassegnati possono essere utilizzati solo per il lato esterno e devono essere sempre protetti internamente da un secondo colore.











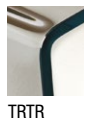













* The marked colours can only be used on the external side and need to be protected by a second internal colour.

PARTY / LIVE - TOP (TABLE H. 74)

design Studio Sovet
1988

Solo top in vetro temperato di varie forme e finiture da sommare alla base prescelta a pag. 33.

Tempered glass top only available in various dimensions and finishes to match bases on page 33.

						FINITURE TOP / TOP FINISHES					
						VETRO FLOAT CLEAR GLASS		VETRO EXTRACHIARO EXTRALIGHT GLASS		ACIDATO FROSTED	
						Clear TRTR	Lacquered Cat. A / C	Extralight TETE	Lacquered Cat. B / D	Frosted AEAE	Lacquered Cat. E
DIMENSIONS cm	BASE	SP. mm / TH. mm	COD.	M ³	KG	€	€	€	€	€	€
Ø 120	①	12 FL45° Temp.	PT120 _ _	0,10	40	370	550	480	660	570	750
Ø 130	①	12 FL45° Temp.	PT121 _ _	0,11	47	440	640	570	780	670	870
Ø 140	① ②	12 FL45° Temp.	PT122 _ _	0,13	54	510	750	660	900	770	1010
Ø 150	②	12 FL45° Temp.	PT123 _ _	0,15	62	580	850	750	1030	890	1160
Ø 170	②	12 FL45° Temp.	PT124 _ _	0,19	80	740	1090	960	1310	1130	1480
160x100	① ③	12 FL45° Temp.	PT420 _ _	0,11	44	410	610	540	730	630	830
180x130	① ②	12 FL45° Temp.	PT421 _ _	0,15	65	600	890	780	1070	920	1210
200x110	① ③	12 FL45° Temp.	PT422 _ _	0,14	61	570	840	740	1010	870	1130
220x130	① ②	12 FL45° Temp.	PT423 _ _	0,19	79	730	1080	950	1300	1120	1470
200x110	① ② ③	12 FL45° Temp.	PT820 _ _	0,14	70	570	840	740	1010	870	1140
						 TRTR		 TETE		 AEAE	
						 TRB2  TRC1  TRN1  TRN2  TRR1  TRMP  TRM1  TRM2  TRM3		 TEA1  TEB1  TEC2  TER2  TER3  TEV1  TEM4  TEM5  TES1		 AEA1  AEB1  AEC1  AEC2	

LEGENDA / LEGEND





































- ① Base consigliata Art. PB050 (vedi pag. 33)
Suggested base item PB050 (please see page 33)
- ② Base consigliata Art. PB060 (vedi pag. 33)
Suggested base item PB060 (please see page 33)
- ③ Base consigliata Art. PB080 (vedi pag. 33)
Suggested base item PB080 (please see page 33)

PARTY / LIVE - TOP (TABLE H. 74)

design Studio Sovet
1988

Solo top in vetro temperato di varie forme e finiture
da sommare alla base prescelta a pag. 33.

*Tempered glass top only available in various dimensions
and finishes to match bases on page 33.*

						FINITURE TOP / TOP FINISHES					
						VETRO FLOAT CLEAR GLASS		VETRO EXTRACHIARO EXTRALIGHT GLASS		ACIDATO FROSTED	
						Clear TRTR	Lacquered Cat. A / C	Extralight TETE	Lacquered Cat. B / D	Frosted AEAE	Lacquered Cat. E
DIMENSIONS cm	BASE	SP. mm / TH. mm	COD.	M ³	KG	€	€	€	€	€	€
	110x110 ①	15 FL / 4 ANG. R=60	PT010 _ _	0,08	50	320	490	450	620	570	740
	130x130 ①②	12 FL / ANG. R=3 Temp.	PT012 _ _	0,11	58	410	610	540	740	640	840
	140x140 ②	15 FL / ANG. R=60 Temp.	PT013 _ _	0,13	82	660	920	870	1140	-	-
	180x90 ①	12 FL / ANG. R=3 Temp.	PT220 _ _	0,11	55	390	590	520	720	610	810
	200x100 ①	12 FL / ANG. R=3 Temp.	PT221 _ _	0,13	68	470	710	620	870	740	990
	250x100 ①②	12 FL / ANG. R=3 Temp.	PT222 _ _	0,16	85	580	880	770	1070	910	1220
	200x100 ①②③	15 FL / ANG. R=5 Temp.	PT223 _ _	0,13	83	650	920	870	1140	1070	1340
	250x100 ①②	15 FL / ANG. R=10 Temp.	PT224 _ _	0,16	104	800	1140	1070	1410	1320	1660
	300x120 ②	12 FL / ANG. R=3 Temp.	PT225 _ _	0,23	123	810	1240	1080	1520	1290	1730
	200x120 ②	15 FL / ANG. R=60 Temp.	PT226 _ _	0,16	100	850	1170	1100	1430	-	-
	220x120 ②	15 FL / ANG. R=60 Temp.	PT227 _ _	0,17	110	930	1290	1220	1570	-	-
	320x120 ②	15 FL / ANG. R=60 Temp.	PT228 _ _	0,25	160	1350	1870	1760	2280	-	-
						 TRTR		 TETE		 AEAE	
						 TRB2  TRC1  TRN1  TRN2  TRR1  TRMP  TRM1  TRM2  TRM3		 TEA1  TEB1  TEC2  TER2  TER3  TEV1  TEM4  TEM5  TES1		 AEA1  AEB1  AEC1  AEC2	

LEGENDA / LEGEND

- ① Base consigliata Art. PB050 (vedi pag. 33)
Suggested base item PB050 (please see page 33)
- ② Base consigliata Art. PB060 (vedi pag. 33)
Suggested base item PB060 (please see page 33)
- ③ Base consigliata Art. PB080 (vedi pag. 33)
Suggested base item PB080 (please see page 33)

PARTY - BASE (TABLE H. 35/39)

design Studio Sovet
1988

Solo basi per tavolini in vetro curvo trasparente, trasparente extrachiaro o laccato, mono o bicolore.

Bent glass bases only for coffee tables in clear, extralight or lacquered, mono or two-tones.

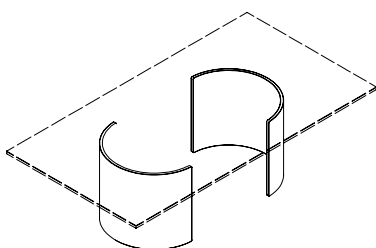
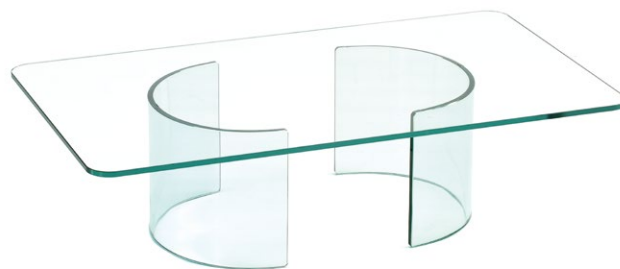























DIMENSIONS cm	SP. / TH.	COD.	M ³	KG	FINITURE BASE / BASE FINISHES					
					VETRO FLOAT CLEAR GLASS			VETRO EXTRACHIARO EXTRALIGHT GLASS		
					Clear TRTR	Lacquered Cat. A	Two-tones Cat. A or C	Extralight TETE	Lacquered Cat. B	Two-tones Cat. B or D
					€	€	€	€	€	€
Ø 42x35h	12 FL - Base only ①	PB042 _ _	0,06	16	250	330	350	280	360	390
Ø 42x39h	12 FL - Base only ②	PB043 _ _	0,07	18	270	350	370	300	380	410
Ø 54x35h	15 FL - Base only ③	PB057 _ _	0,10	24	350	460	490	420	530	560

TOP CONSIGLIATI / SUGGESTED TOP

- ① **BASE ART. PB042**
Vedi top abbinabili a pag. 73 /
Please see matching tops on page. 73
- ② **BASE ART. PB043**
Vedi top abbinabili a pag. 73 /
Please see matching tops on page. 73
- ③ **BASE ART. PB057**
Vedi top abbinabili a pag. 73 /
Please see matching tops on page. 73

* I colori contrassegnati possono essere utilizzati solo per il lato esterno e devono essere sempre protetti internamente da un secondo colore.

* The marked colours can only be used on the external side and need to be protected by a second internal colour.

































TRTR	TETE
 TRB2  TRC1  TRN1  TRN2  TRR1  TRMP	 TEA1  TEB1  TEC2  TER2  TER3  TEV1
 TRM1 *  TRM2 *  TRM3 *	 TEA1 *  TEB1  TEC2  TER2  TER3  TEV1  TEM4 *  TEM5 * TES1 *

PARTY - TOP (TABLE H. 35/39)

design Studio Sovet
1988

Solo top in vetro di varie forme, dimensioni e finiture da sommare alla base prescelta a pag. 66.

Glass top only, various shapes, dimensions and finishes to match base on page 66.

						FINITURE TOP / TOP FINISHES					
						VETRO FLOAT CLEAR GLASS		VETRO EXTRACHIARO EXTRALIGHT GLASS		ACIDATO FROSTED	
						Clear TRTR	Lacquered Cat. A / C	Extralight TETE	Lacquered Cat. B / D	Frosted AEAE	Lacquered Cat. E
DIMENSIONS cm	BASE	SP. mm / TH. mm	COD.	M ³	KG	€	€	€	€	€	€
 90x90	① ②	15 FL / 4 ANG. R=60	PT009 _ _	0,06	34	220	330	310	420	390	500
 110x110	③	15 FL / ANG. R=60	PT010 _ _	0,08	50	320	490	450	620	570	740
 130x70	① ② ③	15 FL / ANG. R=60	PT218 _ _	0,06	38	240	370	340	470	430	560
 130x70	① ②	12 FL / ANG. R=5 Temp.	PT217 _ _	0,06	31	210	320	280	390	340	450
 140x80	③	15 FL / ANG. R=60	PT219 _ _	0,08	47	300	450	420	570	530	690
 Ø 100	③	15 FL	PT119 _ _	0,07	34	270	400	380	510	480	610
 130x70	① ②	12 FL45° Temp.	PT819 _ _	0,06	29	190	310	260	380	320	430
						 TRTR	 TRB2  TRC1  TRN1  TRN2  TRR1  TRMP  TRM1  TRM2  TRM3	 TETE	 TEA1  TEB1  TEC2  TER2  TER3  TEV1  TEM4  TEM5  TES1	 AEAE	 AEA1  AEB1  AEC1  AEC2

LEGENDA / LEGEND

- ① Base consigliata Art. PB042 (vedi pag. 72)
Suggested base item PB042 (please see page 72)
- ② Base consigliata Art. PB043 (vedi pag. 72)
Suggested base item PB043 (please see page 72)
- ③ Base consigliata Art. PB057 (vedi pag. 72)
Suggested base item PB057 (please see page 72)





SLIM 10 - H. 74

design Matthias Demacker
2011

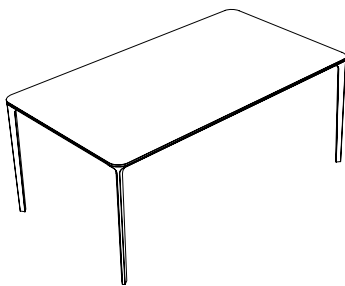
Tavolo con gambe in alluminio pressofuso cromato o verniciato e struttura con profilo in alluminio anodizzato o verniciato. Piano in vetro temperato sp. 10 mm disponibile in vari colori e finiture.

Dining table with die-cast aluminium legs, polished chrome finish or lacquered and anodized or lacquered aluminium structure profile. Tempered glass top, th. 10 mm, available in various finishes and colours.



DIMENSIONS cm	SP. / TH. TOP	COD.	M ³	KG
 120x80	10 BC	P1660 _ _ _ _	0,17	45
 140x80	10 BC	P1662 _ _ _ _	0,18	50
 140x90	10 BC	P1663 _ _ _ _	0,20	54
 160x90	10 BC	P1664 _ _ _ _	0,22	60
 200x90	10 BC	P1666 _ _ _ _	0,25	72

FINITURE TOP / TOP FINISHES

VETRO FLOAT	VETRO EXTRALIGHT	LAMINATO HPL LAMINATE HPL	
		Laminato HN	Laminato H4
Lacquered Cat. A / C	Lacquered Cat. B / D	€	€
€	€	€	€
1050	1130	1180	1400
1120	1220	1200	1430
1180	1290	1210	1430
1260	1390	1230	1460
1410	1560	1260	1510

FINITURE STRUTTURA / STRUCTURE FINISHES

Alluminio anodizzato / Anodized aluminium



OA

Alluminio laccato / Lacquered aluminium



FB

FN

FT

FC

FINITURE GAMBE / LEGS FINISHES

Alluminio cromato / Polished chrome aluminium



LC

Alluminio laccato / Lacquered aluminium



FB

FN

FT

FC



TRB2



TRC1



TRN1



TRN2



TRR1



TRMP



TRM1



TRM2



TRM3



TEA1



TEB1



TEC2



TER2



TER3



TEV1



TEM4



TEM5



TES1



HN



H4

SLIM 10 - EXTENSIBLE H. 74

design Matthias Demacker
2011

Tavolo allungabile con gambe in alluminio pressofuso cromato lucido o verniciato e struttura con profilo in alluminio anodizzato o verniciato. Piano in vetro temperato sp. 10 mm disponibile in vari colori e finiture, o in hpl. Prolunga in hpl bianco o nero.

Extensible dining table with die-cast aluminium legs, polished chrome finish or lacquered and anodized or lacquered aluminium structure profile. Tempered glass top, th. 10 mm, available in various finishes and colours or in hpl. Black or white extension in hpl.

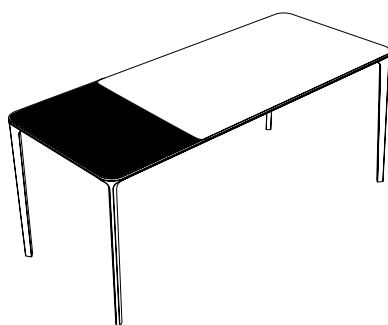

DIMENSIONS cm	SP. / TH. TOP	EXTENSION	COD.	M ³	KG
Close 120x80 Open 175x80	10 BC	Black	P1686 __ __ HN	0,17	57
		White	P1686 _ _ H4	0,17	57
Close 140x80 Open 195x80	10 BC	Black	P1688 __ __ HN	0,18	63
		White	P1688 _ _ H4	0,18	63
Close 140x90 Open 200x90	10 BC	Black	P1689 __ __ HN	0,20	69
		White	P1689 _ _ H4	0,20	69
Close 160x90 Open 220x90	10 BC	Black	P1690 __ __ HN	0,22	76
		White	P1690 _ _ H4	0,22	76

FINITURE STRUTTURA / STRUCTURE FINISHES

Alluminio anodizzato / Anodized aluminium



OA

Alluminio laccato / Lacquered aluminium



FB

FN

FT

FC

FINITURE GAMBE / LEGS FINISHES

Alluminio cromato / Polished chrome aluminium



LC

Alluminio laccato / Lacquered aluminium



FB

FN

FT

FC

FINITURE TOP / TOP FINISHES

VETRO FLOAT	VETRO EXTRALIGHT	LAMINATO HPL LAMINATE HPL	
		Laminato HN	Laminato H4
Lacquered Cat. A / C	Lacquered Cat. B / D	€	€
€	€	€	€
1630	1710	1760	1980
1750	1830	1880	2100
1770	1870	1850	2070
1890	1990	1970	2190
1830	1940	1870	2090
1950	2060	1990	2210
1930	2050	1900	2120
2050	2170	2020	2240

TRB2 TRC1 TRN1 TRN2 TRR1 TRMP TRM1 TRM2 TRM3	TEA1 TEB1 TEC2 TER2 TER3 TEV1 TEM4 TEM5 TES1	HN H4
--	--	----------

SLIM 8 GLASS - SQUARE H. 74

design Matthias Demacker
2011

Tavolo con gambe in alluminio pressofuso cromato o verniciato, varie finiture, e struttura con profilo in alluminio anodizzato o verniciato, varie finiture. Piano in vetro temperato sp. 8 mm laccato o acidato laccato, vari colori. Versione outdoor disponibile su richiesta.

Dining table with die-cast aluminium legs, polished chrome finish or lacquered, various finishes, and anodized or lacquered, various finishes, aluminium structure profile. Tempered glass top, th. 8 mm, lacquered or frosted lacquered, various colours. Outdoor version available on demand.

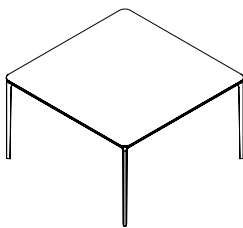

DIMENSIONS cm	SP. / TH. TOP	COD.	M ³	KG
90x90	8 FL	P1722 _ _	0,15	36
100x100	8 FL	P1723 _ _	0,17	40
120x120	8 FL	P1724 _ _	0,21	53
130x130	8 FL	P1726 _ _	0,24	60
140x140	8 FL	P1728 _ _	0,27	67
160x160	8 FL	P1730 _ _	0,33	82

FINITURE TOP / TOP FINISHES

VETRO FLOAT CLEAR GLASS	VETRO EXTRALIGHT EXTRALIGHT GLASS	ACIDATO FROSTED	CIRCLES CIRCLES
Lacquered Cat. A / C	Lacquered Cat. B / D	Lacquered Cat. E	Circles Cat. O
€	€	€	€
850	890	930	990
920	980	1020	1100
1070	1160	1220	1340
1100	1210	1280	1420
1220	1340	1430	1580
1400	1560	1670	1870

FINITURE STRUTTURA / STRUCTURE FINISHES			
<p>Alluminio anodizzato / Anodized aluminium</p> <p>OA</p>	<p>Alluminio laccato / Lacquered aluminium</p> <p>FB FN FT FC</p>		
<p>Alluminio cromato / Polished chrome aluminium</p> <p>LC</p>	<p>Alluminio laccato / Lacquered aluminium</p> <p>FB FN FT FC</p>		

TRB2 TRC1 TRN1 TRN2 TRR1 TRMP TRM1 TRM2 TRM3	TEA1 TEB1 TEC2 TER2 TER3 TEV1 TEM4 TEM5 TES1	AEA1 AEB1 AEC1 AEC2	O1M3 O1S1
--	--	------------------------------	--------------

SLIM 8 GLASS - RECTANGULAR H. 74

design Matthias Demacker
2011

Tavolo con gambe in alluminio pressofuso cromato o verniciato, varie finiture, e struttura con profilo in alluminio anodizzato o verniciato, varie finiture. Piano in vetro temperato sp. 8 mm laccato o acidato vari colori. Versione outdoor disponibile su richiesta.

Dining table with die-cast aluminium legs, polished chrome finish or lacquered, various finishes, and anodized or lacquered, various finishes, aluminium structure profile. Tempered glass top, th. 8 mm, lacquered or frosted lacquered, various colours. Outdoor version available on demand

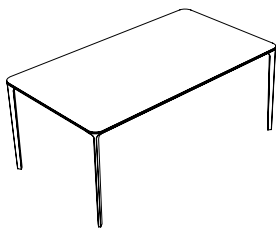

DIMENSIONS cm	SP. / TH. TOP	COD.	M ³	KG
120x80	8 FL	P1732 __	0,17	40
140x90	8 FL	P1736 __	0,20	48
160x90	8 FL	P1738 __	0,22	53
200x90	8 FL	P1740 __	0,25	63
200x100	8 FL	P1741 __	0,28	70
220x100	8 FL	P1744 __	0,29	74
220x120	8 FL	P1745 __	0,34	85
240x100	8 FL	P1746 __	0,32	80
240x120	8 FL	P1748 __	0,37	86

FINITURE TOP / TOP FINISHES

VETRO FLOAT CLEAR GLASS	VETRO EXTRALIGHT EXTRALIGHT GLASS	ACIDATO FROSTED	CIRCLES CIRCLES
Lacquered Cat. A / C	Lacquered Cat. B / D	Lacquered Cat. E	Circles Cat. O
€	€	€	€
920	980	1020	1100
1020	1100	1150	1250
1080	1170	1230	1350
1160	1270	1350	1530
1250	1370	1460	1620
1400	1530	1630	1880
1560	1720	1830	2040
1490	1640	1740	1940
1620	1800	1920	2150

FINITURE STRUTTURA / STRUCTURE FINISHES

Alluminio anodizzato / Anodized aluminium



OA

Alluminio laccato / Lacquered aluminium



FB

FN

FT

FC

FINITURE GAMBE / LEGS FINISHES

Alluminio cromato / Polished chrome aluminium



LC

Alluminio laccato / Lacquered aluminium



FB

FN

FT

FC



TRB2



TRC1



TRN1



TRN2



TRR1



TRMP



TRM1



TRM2



TRM3



TEA1



TEB1



TEC2



TER2



TER3



TEV1



TEM4



TEM5



TES1



AEA1



AEB1



AEC1



AEC2



O1M3

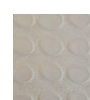

O1S1

SLIM 8 OFFICE - H. 74

design Studio Sovet
2013

Tavolo con gambe in alluminio pressofuso cromato o verniciato, varie finiture, e struttura con profilo in alluminio anodizzato o verniciato, varie finiture. Piano in vetro temperato sp. 8 mm laccato o acidato laccato, vari colori. Accessorio portadocumenti in alluminio laccato, vari colori.

Dining table with die-cast aluminium legs, polished chrome finish or lacquered, various finishes, and anodized or lacquered, various finishes, aluminium structure profile. Tempered glass top, th. 8 mm, lacquered or frosted lacquered, various colours. Lacquered aluminium documents tray, various colours.

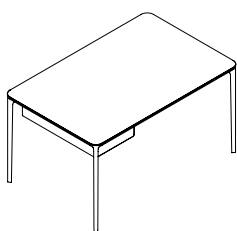

DIMENSIONS cm	SP. / TH. TOP	COD.	M ³	KG
140x90	8 FL	P1736 _ _	0,20	48
160x90	8 FL	P1738 _ _	0,22	53
200x90	8 FL	P1740 _ _	0,25	63
Vassoio / Tray	FB / FN / FT / FC	P1749 _ _	0,07	4

FINITURE TOP / TOP FINISHES

VETRO FLOAT CLEAR GLASS	VETRO EXTRALIGHT EXTRALIGHT GLASS	ACIDATO FROSTED
Lacquered Cat. A / C	Lacquered Cat. B / D	Lacquered Cat. E
€	€	€
1020	1100	1150
1080	1170	1230
1160	1270	1350
130	130	130

FINITURE STRUTTURA / STRUCTURE FINISHES

Alluminio anodizzato / Anodized aluminium



OA

Alluminio laccato / Lacquered aluminium



FB

FN

FT

FC

FINITURE GAMBE / LEGS FINISHES

Alluminio cromato / Polished chrome aluminium



LC

Alluminio laccato / Lacquered aluminium



FB

FN

FT

FC

FINITURE RIPIANO / SHELF FINISHES

Alluminio laccato / Lacquered aluminium



FB

FN

FT

FC



TRB2



TRC1



TRN1



TRN2



TRR1



TRMP



TRM1



TRM2



TRM3



TEA1



TEB1



TEC2



TER2



TER3



TEV1



TEM4



TEM5



TES1



AEA1



AEB1



AEC1



AEC2

SLIM 8 GLASS - EXTENSIBLE H. 74

design Matthias Demacker
2011

Tavolo allungabile con gambe in alluminio pressofuso cromato lucido o verniciato, varie finiture, e struttura con profilo in alluminio anodizzato o verniciato, varie finiture. Piano e prolunga in vetro temperato sp. 8 mm laccato o acidato laccato, vari colori.

Extensible dining table with die-cast aluminium legs, polished chrome finish or lacquered, various finishes, and anodized or lacquered, various finishes, aluminium structure profile. Tempered glass top and extensions, th. 8 mm, lacquered or frosted lacquered, various colours.

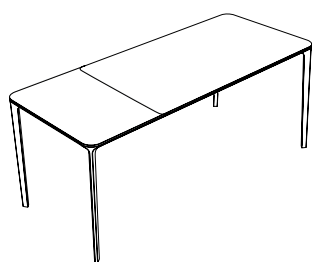

DIMENSIONS cm	SP. / TH. TOP	COD.	M ³	KG
Close 120x80 Open 175x80	8 FL	P1710 __	0,17	55
Close 140x90 Open 200x90	8 FL	P1714 __	0,20	66
Close 160x90 Open 220x90	8 FL	P1716 __	0,22	71
Close 200x90 Open 260x90	8 FL	P1718 __	0,25	81

FINITURE STRUTTURA / STRUCTURE FINISHES

Alluminio anodizzato / Anodized aluminium



OA

Alluminio laccato / Lacquered aluminium



FB

FN

FT

FC

FINITURE GAMBE / LEGS FINISHES

Alluminio cromato / Polished chrome aluminium



LC

Alluminio laccato / Lacquered aluminium



FB

FN

FT

FC

FINITURE TOP / TOP FINISHES

VETRO FLOAT CLEAR GLASS	VETRO EXTRALIGHT EXTRALIGHT GLASS	ACIDATO FROSTED	CIRCLES CIRCLES
Lacquered Cat. A / C	Lacquered Cat. B / D	Lacquered Cat. E	Circles Cat. O
€	€	€	€
1360	1440	1500	1600
1540	1650	1720	1850
1620	1730	1820	1960
1780	1920	2020	2190

SLIM WOOD SQUARE H.74

design Matthias Demacker
2011

Tavolo con gambe in alluminio pressofuso cromato o verniciato in varie finiture. Struttura con profilo in alluminio anodizzato o verniciato, varie finiture. Piano in multistrato di legno di betulla finlandese spessore 10 mm impiallacciato varie finiture.

Dining table with die-cast aluminium legs, polished chrome finish or lacquered, various finishes. Structure with anodized or lacquered aluminium profile. Multi-layer Finnish birch wood top 10mm. thickness, veneered in various finishes.

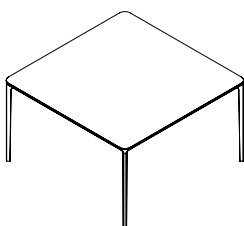

FINITURE TOP / TOP FINISHES

DIMENSIONS cm	SP. / TH. TOP	COD.	M ³	KG
 90x90	10 BC	P1722 __	0,15	27
 120x120	10 BC	P1724 __	0,22	36
 140x140	10 BC	P1728 __	0,27	43

LEGNO WOOD		
NOCE Canaletto Canaletto WALNUT	ROVERE OAK	ROVERE taglio sega saw cut OAK
€	€	€
1130	1130	1150
1480	1480	1580
1860	1860	1910

 NC	 RN	 R5
	 RG	 R6
	 WG	 R7

FINITURE STRUTTURA / STRUCTURE FINISHES

Alluminio anodizzato / Anodized aluminium



OA

Alluminio laccato / Lacquered aluminium



FB

FN

FT

FC

FINITURE GAMBE / LEGS FINISHES

Alluminio cromato / Polished chrome aluminium



LC

Alluminio laccato / Lacquered aluminium



FB

FN

FT

FC

SLIM WOOD RECTANGULAR H.74

design Matthias Demacker
2011

Tavolo con gambe in alluminio pressofuso cromato o verniciato in varie finiture. Struttura con profilo in alluminio anodizzato o verniciato, varie finiture. Piano in multistrato di legno di betulla finlandese spessore 10 mm impiallacciato varie finiture.

Dining table with die-cast aluminium legs, polished chrome finish or lacquered, various finishes. Structure with anodized or lacquered aluminium profile. Multi-layer Finnish birch wood top 10mm. thickness, veneered in various finishes.

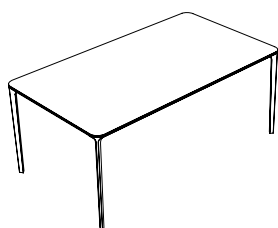

FINITURE TOP / TOP FINISHES

DIMENSIONS cm	SP. / TH. TOP	COD.	M ³	KG	LEGNO WOOD		
					NOCE Canaletto Canaletto WALNUT	ROVERE OAK	ROVERE taglio sega saw cut OAK
					€	€	€
120x80	10 BC	P1732 __	0,17	29	1290	1290	1310
140x90	10 BC	P1736 __	0,20	34	1320	1320	1340
160x90	10 BC	P1738 __	0,22	36	1500	1500	1540
200x90	10 BC	P1740 __	0,25	42	1680	1680	1730
240x120	10 BC	P1748 __	0,37	48	2420	2420	2530

FINITURE STRUTTURA / STRUCTURE FINISHES

Alluminio anodizzato / Anodized aluminium



OA

Alluminio laccato / Lacquered aluminium



FB

FN

FT

FC

FINITURE GAMBE / LEGS FINISHES

Alluminio cromato / Polished chrome aluminium



LC

Alluminio laccato / Lacquered aluminium



FB

FN

FT

FC

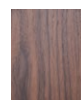

NC



RN

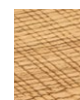

R5

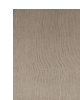

RG

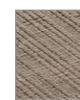

R6



WG



R7





SLIM WOOD - EXTENSIBLE H.74

design Matthias Demacker
2011

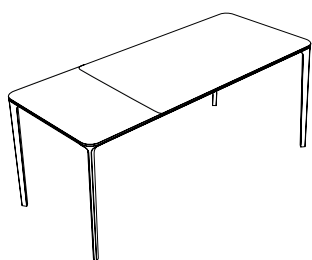





Tavolo allungabile con gambe in alluminio pressofuso cromato o verniciato in varie finiture, struttura con profilo in alluminio anodizzato o verniciato, varie finiture. Piano e allunga in multistrato di legno di betulla finlandese spessore 10 mm impiallacciato varie finiture.

Extensible dining table with die-cast aluminium legs, polished chrome finish or lacquered, various finishes. Structure with anodized or lacquered aluminium profile. Multi-layer Finnish birch wood top and extensions 10mm. thickness, veneered in various finishes.



DIMENSIONS cm	SP. / TH. TOP	COD.	M ³	KG
 Close 120x80 Open 175x80	10 BC / 8 FL	P1710 __	0,17	38
 Close 140x90 Open 200x90	10 BC / 8 FL	P1714 __	0,20	45
 Close 160x90 Open 220x90	10 BC / 8 FL	P1716 __	0,22	48
 Close 200x90 Open 260x90	10 BC / 8 FL	P1718 __	0,25	55

FINITURE TOP / TOP FINISHES

LEGNO WOOD		
NOCE Canaletto Canaletto WALNUT	ROVERE OAK	ROVERE taglio sega saw cut OAK
€	€	€
-	-	-
2060	2060	2100
2250	2250	2300
2490	2490	2550
 NC	 RN	 R5
	 RG	 R6
	 WG	 R7

FINITURE STRUTTURA / STRUCTURE FINISHES

Alluminio anodizzato / Anodized aluminium



OA

Alluminio laccato / Lacquered aluminium



FB

FN

FT

FC

FINITURE GAMBE / LEGS FINISHES

Alluminio cromato / Polished chrome aluminium



LC

Alluminio laccato / Lacquered aluminium



FB

FN

FT

FC

SLIM CERAMIC H.74

design Matthias Demacker
2011

Tavolo con gambe in alluminio pressofuso cromato o verniciato in varie finiture. Struttura con profilo in alluminio anodizzato o verniciato, varie finiture. Piano in ceramica disponibile nelle tonalità sale, roccia e piombo.

Dining table with die-cast aluminum legs, in polished chrome or lacquered finish, various colours. Anodized or lacquered aluminum structure, various finishes. Ceramic top available in the shades SALE, ROCCIA and PIOMBO.

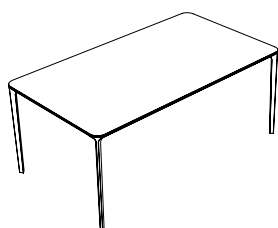

DIMENSIONS cm	SP. / TH. TOP	COD.	M ³	KG	€
90x90	5	P1722 _ _	0,15	33	1080
100x100	5	P1723 _ _	0,17	37	1210
120x80	5	P1732 _ _	0,17	37	1200
140x90	5	P1736 _ _	0,20	44	1390
160x90	5	P1738 _ _	0,22	48	1510
200x90	5	P1740 _ _	0,25	56	1730
200x100	5	P1741 _ _	0,28	60	1840
220x100	5	P1744 _ _	0,30	65	2050
240x100	5	P1746 _ _	0,32	69	2200

FINITURE TOP / TOP FINISHES

CERAMICA
CERAMIC

FINITURE STRUTTURA / STRUCTURE FINISHES

Alluminio anodizzato / Anodized aluminium



OA

Alluminio laccato / Lacquered aluminium



FB

FN

FT

FC

FINITURE GAMBE / LEGS FINISHES

Alluminio cromato / Polished chrome aluminium



LC

Alluminio laccato / Lacquered aluminium



FB

FN

FT

FC



CS



CR



CP

SLIM CERAMIC - EXTENSIBLE H.74

design Matthias Demacker
2011



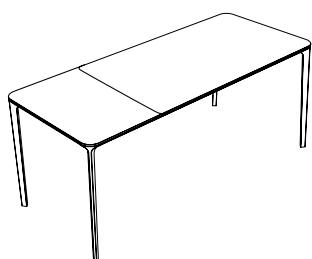

Tavolo allungabile con gambe in alluminio pressofuso cromato o verniciato in varie finiture, struttura con profilo in alluminio anodizzato o verniciato, varie finiture. Piano in ceramica disponibile nelle tonalità sale, roccia e piombo.

Extensible dining table with die-cast aluminum legs in polished chrome or lacquered finish, various colours. Anodized or lacquered aluminum structure, various finishes. Ceramic top available in the shades SALE, ROCCIA and PIOMBO.



FINITURE TOP / TOP FINISHES

CERAMICA
CERAMIC

DIMENSIONS cm	SP. / TH. TOP	COD.	M ³	KG	€
 Close 120x80 Open 175x80	5	P1710 __	0,17	47	1760
 Close 140x90 Open 200x90	5	P1714 __	0,18	56	2050
 Close 160x90 Open 220x90	5	P1716 __	0,22	62	2180
 Close 200x90 Open 260x90	5	P1718 __	0,25	71	2450

FINITURE STRUTTURA / STRUCTURE FINISHES

Alluminio anodizzato / Anodized aluminium



OA

Alluminio laccato / Lacquered aluminium



FB FN FT FC



CS



CR



CP

FINITURE GAMBE / LEGS FINISHES

Alluminio cromato / Polished chrome aluminium



LC

Alluminio laccato / Lacquered aluminium



FB FN FT FC

SLIM 8 GLASS-CERAMIC - H. 37

design Matthias Demacker
2013

Tavolino con gambe in alluminio pressofuso cromato o verniciato, varie finiture. Struttura con profilo in alluminio anodizzato o verniciato, varie finiture. Piano disponibile in vetro temperato sp. 8 mm laccato o acidato laccato, vari colori o in ceramica in varie finiture.

Coffee table with die-cast aluminium legs, polished chrome finish or lacquered, various finishes, and anodized or lacquered, various finishes, aluminium structure profile. Top available in tempered lacquered or frosted lacquered glass 8 mm, various colours or in ceramic, various finishes.

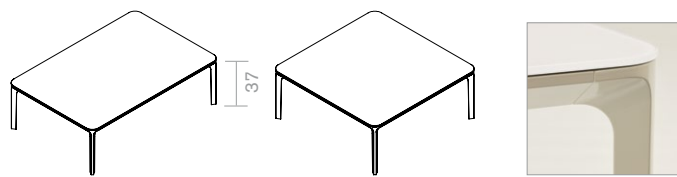

DIMENSIONS cm	SP. / TH. TOP	COD.	M ³	KG
90x90x37h	8 FL / 5	P4882 __	0,16	32
100x100x37h	8 FL / 5	P4883 __	0,14	34
120x120x37h	8 FL / 5	P4884 __	0,19	49
120x80x37h	8 FL / 5	P4902 __	0,18	37
140x90x37h	8 FL / 5	P4908 __	0,21	45
90x45x37h	8 FL / 5	P4891 __	0,12	21
120x45x37h	8 FL / 5	P4893 __	0,14	25
140x45x37h	8 FL / 5	P4895 __	0,15	28
160x45x37h	8 FL / 5	P4896 __	0,16	31
200x45x37h	8 FL / 5	P4898 __	0,15	32

FINITURE TOP / TOP FINISHES

VETRO FLOAT CLEAR GLASS	VETRO EXTRALIGHT EXTRALIGHT GLASS	ACIDATO FROSTED	CIRCLES CIRCLES	CERAMICA CERAMIC
Lacquered Cat. A / C	Lacquered Cat. B / D	Lacquered Cat. E	Circles Cat. O	
€	€	€	€	€
830	870	910	970	1060
900	960	1000	1080	1190
1050	1140	1200	1320	1480
900	960	1000	1080	1180
1000	1080	1130	1230	1370
700	720	740	770	820
760	790	820	860	920
790	830	860	910	980
850	890	920	980	1060
900	950	990	1060	1160

FINITURE STRUTTURA / STRUCTURE FINISHES

Alluminio anodizzato / Anodized aluminium



OA

Alluminio laccato / Lacquered aluminium



FB

FN

FT

FC

FINITURE GAMBE / LEGS FINISHES

Alluminio cromato / Polished chrome aluminium



LC

Alluminio laccato / Lacquered aluminium



FB

FN

FT

FC



TRB2



TRC1



TRN1



TRN2



TRR1



TRMP



TRM1



TRM2



TRM3



TEA1



TEB1



TEC2



TER2



TER3



TEV1



TEM4



TEM5



TES1



AEA1



AEB1



AEC1



AEC2



O1M3



O1S1



CS



CR



CP



CR



CP

SLIM 8 GLASS-CERAMIC - H. 46

design Matthias Demacker
2013

Tavolino con gambe in alluminio pressofuso cromato o verniciato, varie finiture. Struttura con profilo in alluminio anodizzato o verniciato, varie finiture. Piano disponibile in vetro temperato sp. 8 mm laccato o acidato laccato, vari colori o in ceramica, varie finiture.

Coffee table with die-cast aluminium legs, polished chrome finish or lacquered, various finishes, and anodized or lacquered, various finishes, aluminium structure profile. Top available in tempered lacquered or frosted lacquered glass 8 mm, various colours or in ceramic, various finishes.

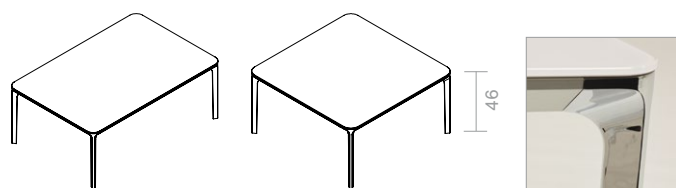

DIMENSIONS cm	SP. / TH. TOP	COD.	M ³	KG
90x90x46h	8 FL / 5	P4922 _ _	0,18	33
100x100x46h	8 FL / 5	P4923 _ _	0,15	35
120x120x46h	8 FL / 5	P4924 _ _	0,20	51
120x80x46h	8 FL / 5	P4942 _ _	0,20	38
140x90x46h	8 FL / 5	P4946 _ _	0,23	46
90x45x46h	8 FL / 5	P4931 _ _	0,14	22
120x45x46h	8 FL / 5	P4933 _ _	0,15	26
140x45x46h	8 FL / 5	P4935 _ _	0,15	29
160x45x46h	8 FL / 5	P4936 _ _	0,17	32
200x45x46h	8 FL / 5	P4938 _ _	0,14	33

FINITURE TOP / TOP FINISHES

VETRO FLOAT CLEAR GLASS	VETRO EXTRALIGHT EXTRALIGHT GLASS	ACIDATO FROSTED	CIRCLES CIRCLES	CERAMICA CERAMIC
Lacquered Cat. A / C	Lacquered Cat. B / D	Lacquered Cat. E	Circles Cat. O	
€	€	€		
835	875	915	975	1065
905	965	1005	1085	1195
1055	1145	1205	1325	1485
905	965	1005	1085	1185
1005	1085	1135	1235	1375
705	725	745	775	825
765	795	825	865	925
795	835	865	915	985
855	895	925	985	1065
905	955	995	1065	1165

FINITURE STRUTTURA / STRUCTURE FINISHES

Alluminio anodizzato / Anodized aluminium



OA

Alluminio laccato / Lacquered aluminium



FB

FN

FT

FC

FINITURE GAMBE / LEGS FINISHES

Alluminio cromato / Polished chrome aluminium



LC

Alluminio laccato / Lacquered aluminium



FB

FN

FT

FC

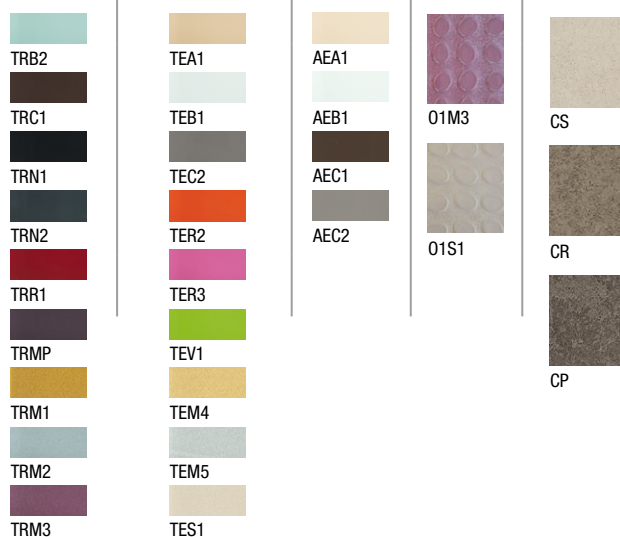

SLIM WOOD - H.37

design Matthias Demacker
2011

Tavolino con gambe in alluminio pressofuso cromato o verniciato in varie finiture, struttura con profilo in alluminio anodizzato o verniciato, varie finiture. Piano in multistrato di legno di betulla finlandese spessore 10 mm impiallacciato varie finiture.

Coffee table with die-cast aluminium legs, polished chrome finish or lacquered, various finishes. Structure with anodized or lacquered aluminium profile. Multi-layer Finnish birch wood top and extensions 10mm. thickness, veneered in various finishes.

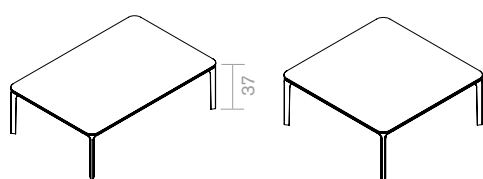

DIMENSIONS cm	SP. / TH. TOP	COD.	M ³	KG
90x90x37h	10 BC	P4882 __	0,16	23
140x140x37h	10 BC	P4888 __	0,25	36
120x80x37h	10 BC	P4902 __	0,18	25
140x90x37h	10 BC	P4908 __	0,21	30
120x45x37h	10 BC	P4893 __	0,14	19
200x45x37h	10 BC	P4898 __	0,15	20

FINITURE TOP / TOP FINISHES

LEGNO WOOD		
NOCE Canaletto Canaletto WALNUT	ROVERE OAK	ROVERE taglio sega saw cut OAK
€	€	€
1110	1110	1130
1840	1840	1890
1270	1270	1290
1300	1300	1320
960	960	980
1210	1210	1240

FINITURE STRUTTURA / STRUCTURE FINISHES

Alluminio anodizzato / Anodized aluminium



OA

Alluminio laccato / Lacquered aluminium



FB



FN



FT



FC

FINITURE GAMBE / LEGS FINISHES

Alluminio cromato / Polished chrome aluminium



LC

Alluminio laccato / Lacquered aluminium



FB



FN



FT



FC



NC



RN



R5



RG



R6



WG



R7

SLIM WOOD - H.46

design Matthias Demacker
2011

Tavolino con gambe in alluminio pressofuso cromato o verniciato in varie finiture, struttura con profilo in alluminio anodizzato o verniciato, varie finiture. Piano in multistrato di legno di betulla finlandese spessore 10 mm impiallacciato varie finiture.

Coffee table with die-cast aluminium legs, polished chrome finish or lacquered, various finishes. Structure with anodized or lacquered aluminium profile. Multi-layer Finnish birch wood top and extensions 10mm. thickness, veneered in various finishes.

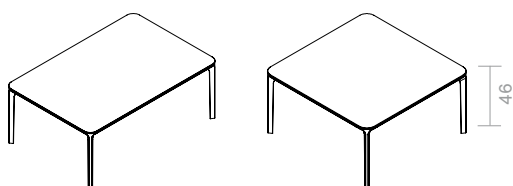

DIMENSIONS cm	SP. / TH. TOP	COD.	M ³	KG
90x90x46h	10 BC	P4922 __	0,13	24
140x140x46h	10 BC	P4828 __	0,26	37
120x80x46h	10 BC	P4942 __	0,15	26
140x90x46h	10 BC	P4946 __	0,18	31
120x45x46h	10 BC	P4933 __	0,10	20
200x45x46h	10 BC	P4938 __	0,14	21

FINITURE TOP / TOP FINISHES

LEGNO WOOD		
NOCE Canaletto Canaletto WALNUT	ROVERE OAK	ROVERE taglio sega saw cut OAK
€	€	€
1115	1115	1135
1845	1845	1895
1275	1275	1295
1305	1305	1325
965	965	865
1215	1215	1245

FINITURE STRUTTURA / STRUCTURE FINISHES

Alluminio anodizzato / Anodized aluminium



OA

Alluminio laccato / Lacquered aluminium



FB

FN

FT

FC

FINITURE GAMBE / LEGS FINISHES

Alluminio cromato / Polished chrome aluminium



LC

Alluminio laccato / Lacquered aluminium



FB

FN

FT

FC



NC



RN



R5



RG



R6



WG



R7

SLIM 8 GLASS-CERAMIC CONSOLE - 2 LEGS

design Matthias Demacker
2012

Console con due gambe in alluminio pressofuso cromato lucido o verniciato, fissaggio a muro. Struttura con profilo in alluminio anodizzato o verniciato, varie finiture. Piano disponibile in vetro temperato sp. 8 mm laccato o acidato laccato, vari colori o in ceramica, varie finiture.

Wall fixable console with two die-cast aluminium legs, lacquered or polished chrome finish. Anodized or lacquered aluminium structure profile, various finishes. Top available in tempered lacquered or frosted lacquered glass 8 mm, various colours or in ceramic, various finishes.

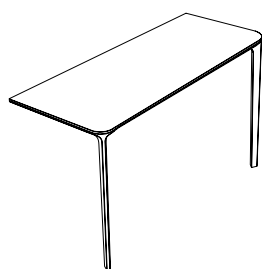

DIMENSIONS cm	SP. / TH. TOP	COD.	M ³	KG
90x40x74h	8 FL / 5	P5180 _ _ _ _	0,10	17
120x40x74h	8 FL / 5	P5182 _ _ _ _	0,11	20
140x40x74h	8 FL / 5	P5184 _ _ _ _	0,12	22
160x40x74h	8 FL / 5	P5185 _ _ _ _	0,13	25

FINITURE TOP / TOP FINISHES

VETRO FLOAT CLEAR GLASS	VETRO EXTRALIGHT EXTRALIGHT GLASS	CIRCLES CIRCLES	ACIDATO FROSTED	CERAMICA CERAMIC
Lacquered Cat. A / C	Lacquered Cat. B / D	Circles Cat. O	Lacquered Cat. E	
€	€	€	€	€
520	550	580	570	580
580	620	660	640	660
620	670	710	700	710
670	720	770	750	780

FINITURE STRUTTURA / STRUCTURE FINISHES

Alluminio anodizzato / Anodized aluminium



OA

Alluminio laccato / Lacquered aluminium



FB

FN

FT

FC

FINITURE GAMBE / LEGS FINISHES

Alluminio cromato / Polished chromed aluminium



LC

Alluminio laccato / Lacquered aluminium



FB

FN

FT

FC

TRB2	TEA1	O1M3	AEA1	CS
TRC1	TEB1	O1S1	AEB1	CR
TRN1	TEC2		AEC1	CP
TRN2	TER2		AEC2	
TRR1	TER3			
TRMP	TEV1			
TRM1	TEM4			
TRM2	TEM5			
TRM3	TES1			

SLIM 8 GLASS-CERAMIC CONSOLE - 4 LEGS

design Matthias Demacker
2012

Console con quattro gambe in alluminio pressofuso cromato o verniciato, varie finiture, e struttura con profilo in alluminio anodizzato o verniciato, varie finiture. Piano disponibile in vetro temperato sp. 8 mm laccato o acidato laccato, vari colori o in ceramica, varie finiture.

Console with four die-cast aluminium legs, polished chrome finish or lacquered, various finishes, and anodized or lacquered, various finishes, aluminium structure profile. Top available in tempered lacquered or frosted lacquered glass 8 mm, various colours or in ceramic, various finishes.

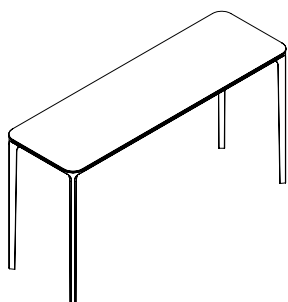

FINITURE TOP / TOP FINISHES

VETRO FLOAT CLEAR GLASS	VETRO EXTRALIGHT EXTRALIGHT GLASS	CIRCLES CIRCLES	ACIDATO FROSTED	CERAMICA CERAMIC					
Lacquered Cat. A / C	Lacquered Cat. B / D	Circles Cat. O	Lacquered Cat. E						
€	€	€	€	€					
90x45x74h	8 FL / 5	P5168 _ _	0,11	25	720	740	790	760	840
120x45x74h	8 FL / 5	P5170 _ _	0,12	29	780	810	880	840	940
140x45x74h	8 FL / 5	P5172 _ _	0,13	32	810	850	930	880	1000
160x45x74h	8 FL / 5	P5174 _ _	0,14	35	870	910	1000	940	1080
200x45x74h	8 FL / 5	P5178 _ _	0,16	37	920	970	1080	1010	1180

FINITURE STRUTTURA / STRUCTURE FINISHES

Alluminio anodizzato / Anodized aluminium



OA

Alluminio laccato / Lacquered aluminium



FB

FN

FT

FC

FINITURE GAMBE / LEGS FINISHES

Alluminio cromato / Polished chromed aluminium



LC

Alluminio laccato / Lacquered aluminium



FB

FN

FT

FC

TRB2	TEA1	O1M3	AEA1	CS
TRC1	TEB1	O1S1	AEB1	CR
TRN1	TEC2		AEC1	CP
TRN2	TER2		AEC2	
TRR1	TER3			
TRMP	TEV1			
TRM1	TEM4			
TRM2	TEM5			
TRM3	TES1			

SLIM WOOD - CONSOLE 4 LEGS

design Matthias Demacker
2011

Console con gambe in alluminio pressofuso cromato o verniciato in varie finiture, struttura con profilo in alluminio anodizzato o verniciato, varie finiture. Piano in multistrato di legno di betulla finlandese spessore 10 mm impiallacciato varie finiture.

Console table with die-cast aluminium legs, polished chrome finish or lacquered aluminium structure profile. Multi-layer Finnish birch wood top and extensions 10mm. thickness, veneered in various finishes.

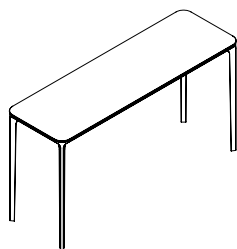

DIMENSIONS cm	SP. / TH. TOP	COD.	M ³	KG
120x45x74h	10 BC	P5170 __	0,12	22
200x45x74h	10 BC	P5178 __	0,16	30

FINITURE TOP / TOP FINISHES

FINITURE TOP / TOP FINISHES		
LEGNO WOOD		
NOCE Canaletto Canaletto WALNUT	ROVERE OAK	ROVERE taglio sega saw cut OAK
€	€	€
980	980	1000
1230	1230	1260
NC	RN	R5
	RG	R6
	WG	R7

FINITURE STRUTTURA / STRUCTURE FINISHES

Alluminio anodizzato / Anodized aluminium



OA

Alluminio laccato / Lacquered aluminium



FB

FN

FT

FC

FINITURE GAMBE / LEGS FINISHES

Alluminio cromato / Polished chrome aluminium



LC

Alluminio laccato / Lacquered aluminium



FB

FN

FT

FC

TORONTO - H. 74

design Mara Panizzo
2004

Tavolo con gambe e struttura in legno impiallacciato, varie finiture. Top in vetro temperato laccato, acidato laccato o placcato, varie finiture.

Dining table with legs and structure in veneered wood, various finishes. Tempered glass top, lacquered or frosted lacquered, various finishes.

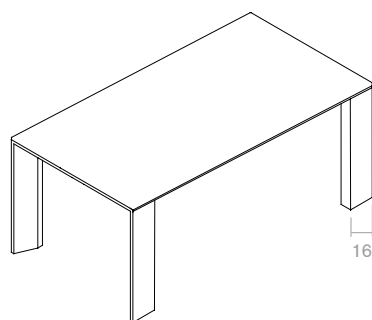

DIMENSIONS cm	TOP	BASE	COD.	M ³	KG
160x90 *	12 FL Temp.	WG/BI/NC	P1584 _ _ _	0,48	96
180x90 *	12 FL Temp.	WG/BI/NC	P1585 _ _ _	0,50	98
200x100	12 FL Temp.	WG/BI/NC	P1586 _ _ _	0,50	120
250x100	12 FL Temp.	WG/BI/NC	P1587 _ _ _	0,54	142
300x120	12 FL Temp.	WG/BI/NC	P1589 _ _ _	0,66	180

FINITURE TOP / TOP FINISHES

VETRO FLOAT CLEAR GLASS	VETRO EXTRACHIARO EXTRALIGHT GLASS		ACIDATO FROSTED
Lacquered Cat. A / C	Lacquered Cat. B / D	Plated Cat. P	Lacquered Cat. E
€	€	€	€
1580	1690	2080	1780
1680	1800	2240	1900
1820	1980	2520	2090
2070	2260	2940	2410
2590	2870	4050	3080

FINITURE BASE / BASE FINISHES

Legno / Wood



WG BI NC

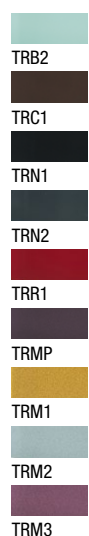

* Queste misure sono disponibili solo fino ad esaurimento scorte.

* These sizes are available just up to stock clearance.

TOTEM - ROUND H. 74

design Studio Sovet
2000

Tavolo con base inox satinato o metallo laccato, varie finiture.
Top in HPL (sp. 12 mm - becco d'oca) o in vetro temperato
laccato, acidato laccato o placcato, vari colori.

*Dining table with mat stainless steel or lacquered metal base,
various finishes. Top in HPL (th. 12 mm) or in tempered glass,
lacquered, frosted lacquered or plated, various colours.*

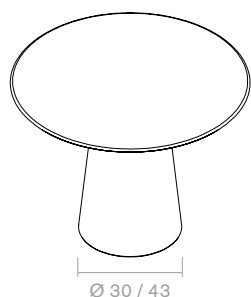

FINITURE TOP / TOP FINISHES

DIMENSIONS cm	TOP	BASE	COD.	M ³	KG	FINITURE TOP / TOP FINISHES				
						€	€	€	€	€
Ø 62	10 BC	Ø 30 FB/FC/FN/FT	P1606 _ _ _	0,11	39	580	610	-	620	-
		Ø 30 IX	P1606IX _ _	0,11	39	740	770	-	780	-
Ø 80	10 BC	Ø 30 FB/FC/FN/FT	P1608 _ _ _	0,13	45	670	720	-	740	-
		Ø 30 IX	P1608IX _ _	0,13	45	830	880	-	900	-
Ø 100	10 BC	Ø 43 FB/FC/FN/FT	P1595 _ _ _	0,26	74	930	1010	-	1050	1100
		Ø 43 IX	P1595IX _ _	0,26	74	1280	1360	-	1400	1450
Ø 120	12 FL45°	Ø 43 FB/FC/FN/FT	P1597 _ _ _	0,28	90	1160	1270	1660	1350	-
		Ø 43 IX	P1597IX _ _	0,28	90	1510	1620	2010	1700	-

FINITURE BASE / BASE FINISHES

Acciaio Inox / Stainless steel



IX

Metallo laccato / Lacquered metal



FB

FC

FN

FT

TRB2	TEA1	TEYO	AEA1	 HB HN
TRC1	TEB1	TEY0	AEB1	
TRN1	TEC2	TEYA	AEC1	
TRN2	TER2	TEYA	AEC2	
TRR1	TER3	TEYR		
TRMP	TEV1			
TRM1	TEM4			
TRM2	TEM5			
TRM3	TES1			

TOTEM - ROUND H. 74

design Studio Sovet
2000

Tavolo con base inox satinato o metallo laccato, varie finiture.
Top in HPL (sp. 12 mm - becco d'oca) o in vetro temperato
laccato, acidato laccato o placcato, vari colori.
Optional: piatto girevole Lazy Susan.

Dining table with mat stainless steel or lacquered metal base, various finishes. Top in HPL (th. 12 mm) or in tempered glass, lacquered, frosted lacquered or plated, various colours. Optional: turning dish Lazy Susan.

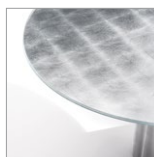
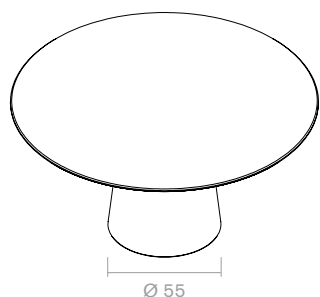

FINITURE TOP / TOP FINISHES

FLOAT GLASS	VETRO EXTRACHIARO EXTRALIGHT GLASS		ACIDATO FROSTED	LAMINATO LAMINATE
-------------	---------------------------------------	--	--------------------	----------------------

Lacquered Cat. A / C	Lacquered Cat. B / D	Plated Cat. P	Lacquered Cat. E	Laminate Cat. HPL
-------------------------	-------------------------	------------------	---------------------	----------------------

€	€	€	€	€
1360	1490	1950	1590	1330
1710	1840	2300	1940	1680
1460	1610	2150	1730	-
1810	1960	2500	2080	-
1570	1740	2350	1880	1460
1920	2090	2700	2230	1810
1810	2030	2810	2200	1640
2160	2380	3160	2550	1990
230	260	410	280	-
270	320	510	350	-

FINITURE BASE / BASE FINISHES

Acciaio Inox / Stainless steel



IX

Metallo laccato / Lacquered metal





FB

FC

FN

FT

TRB2	TEA1	TEY0	AEA1	 HB  HN
TRC1	TEB1	TEY1	AEB1	
TRN1	TEC2	TEY2	AEC1	
TRN2	TER2	TEY3	AEC2	
TRR1	TER3	TEY4		
TRMP	TEV1	TEYR		
TRM1	TEM4			
TRM2	TEM5			
TRM3	TES1			

TOTEM WOOD - ROUND H. 74

design Studio Sovet
2000

Tavolo con base inox satinato o metallo laccato, varie finiture.
Piano in multistrato di legno di betulla finlandese spessore 26 mm,
con bordo a vista tagliato a 45°, impiallacciato noce oppure rovere
sia in finitura spazzolata che taglio a sega.

Dining table with stainless steel or lacquered metal base, various finishes. Multi-layer Finnish birch wood top 26mm. thickness, 45°-cut edge, walnut or oak veneered, brushed or saw cut finish.

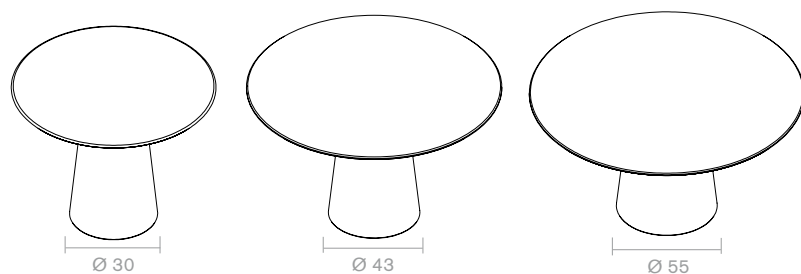

DIMENSIONS cm	TOP	BASE	COD.	M ³	KG	FINITURE TOP / TOP FINISHES		
						NOCE Canaletto Canaletto WALNUT	ROVERE OAK	ROVERE taglio sega saw cut OAK
Ø 62	26	Ø 30 FB/FC/FN/FT	P1606 _ _ _	0,11	37	€ 660	€ 660	€ 670
		Ø 30 IX	P1606IX _ _	0,11	37	€ 820	€ 820	€ 830
Ø 90	26	Ø 43 FB/FC/FN/FT	P1591 _ _	0,14	42	€ 970	€ 970	€ 980
		Ø 43 IX	P1591IX _ _	0,14	42	€ 1320	€ 1320	€ 1330
Ø 130	26	Ø 55 FB/FC/FN/FT	P1598 _ _ _	0,37	72	€ 1610	€ 1610	€ 1640
		Ø 55 IX	P1598IX _ _	0,37	72	€ 1960	€ 1960	€ 1990
Ø 150	26	Ø 55 FB/FC/FN/FT	P1600 _ _ _	0,41	78	€ 1940	€ 1940	€ 1980
		Ø 55 IX	P1600IX _ _	0,41	78	€ 2290	€ 2290	€ 2330
Ø 180	26	Ø 55 FB/FC/FN/FT	P1590 _ _ _	0,47	100	€ 2150	€ 2150	€ 2190
		Ø 55 IX	P1590IX _ _	0,47	100	€ 2500	€ 2500	€ 2540

FINITURE BASE / BASE FINISHES

Acciaio Inox / Stainless steel



IX

Metallo laccato / Lacquered metal



FB FC FN FT



NC



RN



R5



RG



R6



WG



R7

TOTEM - SHAPED H. 74

design Studio Sovet
2000

Tavolo con base inox satinato o metallo laccato, varie finiture.
Top in HPL (sp. 12 mm - becco d'oca) o in vetro temperato
laccato, acidato laccato o placcato, vari colori.

*Dining table with mat stainless steel or lacquered metal base,
various finishes. Top in HPL (th. 12 mm) or in tempered glass,
lacquered, frosted lacquered or plated, various colours.*

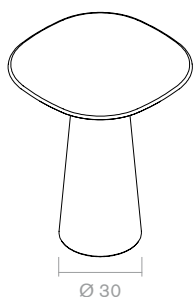

FINITURE TOP / TOP FINISHES

DIMENSIONS cm	TOP	BASE	COD.	M ³	KG	FINITURE TOP / TOP FINISHES			
						VETRO GLASS	VETRO EXTRACHIARO EXTRALIGHT GLASS	ACIDATO FROSTED	LAMINATO LAMINATE
						Lacquered Cat. A / C	Lacquered Cat. B / D	Lacquered Cat. E	Laminare Cat. HPL
						€	€	€	€
62x62	10 BC	FB/FC/FN/FT	P1607 _ _ _	0,11	39	580	610	620	670
		IX	P1607IX _ _	0,11	39	740	770	780	830
80x80	10 BC	FB/FC/FN/FT	P1609 _ _ _	0,13	46	670	720	740	770
		IX	P1609IX _ _	0,13	46	830	880	900	930

FINITURE BASE / BASE FINISHES

Acciaio Inox / Stainless steel



IX

Metallo laccato / Lacquered metal



FB

FC

FN

FT



TRB2



TRC1



TRN1



TRN2



TRR1



TRMP



TRM1



TRM2



TRM3



TEA1



TEB1



TEC2



TER2



TER3



TEV1



TEM4



TEM5



TES1



AEA1



AEB1



AEC1



AEC2



HB



HN

TOTEM - SHAPED H. 74

design Studio Sovet
2000

Tavolo con base inox satinato o metallo laccato, varie finiture.
Top in HPL (sp. 12 mm - becco d'oca) o in vetro temperato
laccato, acidato laccato o placcato, vari colori.

Dining table with mat stainless steel or lacquered metal base, various finishes. Top in HPL (th. 12 mm) or in tempered glass, lacquered, frosted lacquered or plated, various colours.

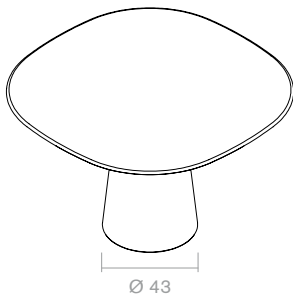

DIMENSIONS cm	TOP	BASE	COD.	M ³	KG
100x100	10 BC	FB/FC/FN/FT	P1596 _ _ _	0,26	75
		IX	P1596IX _ _	0,26	75
120x120	12 BC	FB/FC/FN/FT	P1599 _ _ _	0,28	92
		IX	P1599IX _ _	0,28	92

FINITURE TOP / TOP FINISHES

VETRO FLOAT CLEAR GLASS	VETRO EXTRACHIARO EXTRALIGHT GLASS		ACIDATO FROSTED	LAMINATO LAMINATE
Lacquered Cat. A / C	Lacquered Cat. B / D	Plated Cat. P	Lacquered Cat. E	Laminate Cat. HPL
€	€	€	€	€
930	1010	-	1050	1100
1280	1360	-	1400	1450
1170	1280	1670	1360	-
1520	1630	2020	1710	-

FINITURE BASE / BASE FINISHES

Acciaio Inox / Stainless steel



IX

Metallo laccato / Lacquered metal



FB

FC

FN

FT

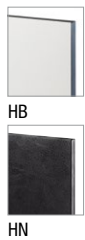
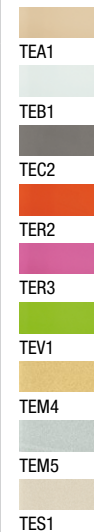
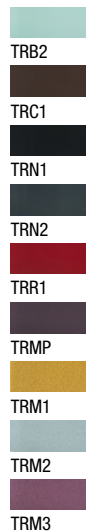

TOTEM - ELLIPTICAL H. 74

design Studio Sovet
2000

Tavolo con base inox satinato o metallo laccato, varie finiture. Top in vetro temperato laccato, acidato laccato o placcato, vari colori.

Dining table with mat stainless steel or lacquered metal base, various finishes. Top in tempered glass, lacquered, frosted lacquered or plated, various colours.

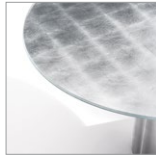
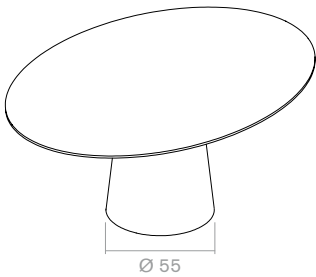

DIMENSIONS cm	TOP	BASE	COD.	M ³	KG
180x130	12 FL45°	FB/FC/FN/FT	P1602 _ _ _	0,42	125
		IX	P1602IX _ _	0,42	125
200x110	12 FL45°	FB/FC/FN/FT	P1603 _ _ _	0,41	121
		IX	P1603IX _ _	0,41	121
220x130	12 FL45°	FB/FC/FN/FT	P1604 _ _ _	0,45	139
		IX	P1604IX _ _	0,45	139

FINITURE TOP / TOP FINISHES

VETRO FLOAT CLEAR GLASS	VETRO EXTRACHIARO EXTRALIGHT GLASS		ACIDATO FROSTED
Lacquered Cat. A / C	Lacquered Cat. B / D	Plated Cat. P	Lacquered Cat. E
€	€	€	€
1600	1780	2420	1920
1950	2130	2770	2270
1550	1720	2320	1850
1900	2070	2670	2200
1800	2020	2790	2190
2150	2370	3140	2540

FINITURE BASE / BASE FINISHES

Acciaio Inox / Stainless steel



IX

Metallo laccato / Lacquered metal



FB FC FN FT



TRB2



TRC1



TRN1



TRN2



TRR1



TRMP



TRM1



TRM2



TRM3



TEA1



TEB1



TEC2



TER2



TER3



TEV1



TEM4



TEM5



TES1



TEYO



TEYA



TEYA



TEYR



TEYR



AEA1



AEB1



AEC1



AEC2

TOTEM - H. 110

design Studio Sovet
2000

Tavolo con base inox satinato o metallo laccato, varie finiture.
Top in HPL (sp. 12 mm - becco d'oca) o in vetro temperato
laccato, acidato laccato o placcato, vari colori.

*Dining table with mat stainless steel or lacquered metal base,
various finishes. Top in HPL (th. 12 mm) or tempered glass,
lacquered, frosted lacquered or plated, various colours.*

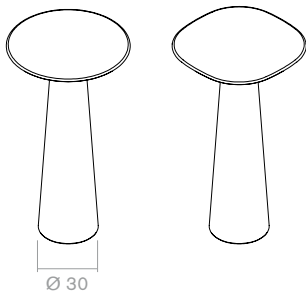

DIMENSIONS cm	TOP	BASE	COD.	M ³	KG
● Ø 62x110h	10 BC	FB/FC/FN/ IX	P1614 _ _ _ P1614IX _ _	0,13 0,13	54 54
■ 62x62x110h	10 BC	FB/FC/FN/ IX	P1615 _ _ _ P1615IX _ _	0,13 0,13	54 54

FINITURE TOP / TOP FINISHES

VETRO FLOAT CLEAR GLASS	VETRO EXTRACHIARO EXTRALIGHT GLASS		ACIDATO FROSTED	LAMINATO LAMINATE
Lacquered Cat. A / C	Lacquered Cat. B / D	Plated Cat. P	Lacquered Cat. E	Laminate Cat. HPL
€	€	€	€	€
830	860	970	870	-
1120	1150	1260	1160	-
830	860	-	870	920
1120	1150	-	1160	1210

FINITURE BASE / BASE FINISHES

Acciaio Inox / Stainless steel



IX

Metallo laccato / Lacquered metal



FB

FC

FN

TRB2	TEA1	TEYO	AEA1	HB
TRC1	TEB1	TEYA	AEB1	
TRN1	TEC2	TEYR	AEC1	HN
TRN2	TER2		AEC2	
TRR1	TER3			
TRMP	TEV1			
TRM1	TEM4			
TRM2	TEM5			
TRM3	TES1			

TOTEM - TWO BASES H. 74

design Studio Sovet
2000

Tavolo con due basi inox satinato o metallo laccato, varie finiture. Top in vetro temperato laccato, acidato laccato o placcato, vari colori.

Dining table with mat stainless steel or lacquered metal bases, various finishes. Top in tempered glass, lacquered, frosted lacquered or plated, various colours.

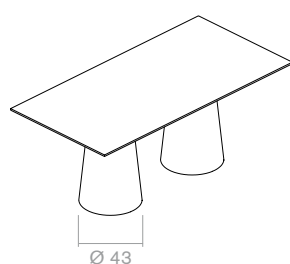

DIMENSIONS cm	TOP	BASE	COD.	M ³	KG
200x100	15 FL	FB/FC/FN/FT	P1611 _ _ _	0,51	180
		IX	P1611IX _ _	0,51	180
250x100	15 FL	FB/FC/FN/FT	P1612 _ _ _	0,54	200
		IX	P1612IX _ _	0,54	200
320x90	15 FL	FB/FC/FN/FT	P1613 _ _ _	0,56	220
		IX	P1613IX _ _	0,56	220
320x120	15 FL	FB/FC/FN/FT	P1700 _ _ _	0,62	260
		IX	P1700IX _ _	0,62	260

FINITURE TOP / TOP FINISHES

VETRO FLOAT CLEAR GLASS	VETRO EXTRACHIARO EXTRALIGHT GLASS		ACIDATO FROSTED
Lacquered Cat. A / C	Lacquered Cat. B / D	Plated Cat. P	Lacquered Cat. E
€	€	€	€
2130	2350	2990	2550
2830	3050	3690	3250
2350	2620	3410	2870
3050	3320	4110	3570
2520	2830	3740	3120
3220	3530	4440	3820
3030	3450	4660	3830
3730	4150	5360	4530

FINITURE BASE / BASE FINISHES

Acciaio Inox / Stainless steel



IX

Metallo laccato / Lacquered metal



FB

FC

FN

FT



TRB2



TRC1



TRN1



TRN2



TRR1



TRMP



TRM1



TRM2



TRM3



TEA1



TEB1



TEC2



TER2



TER3



TEV1



TEM4



TEM5



TES1



TEYO



TEYA



TEYR



AEA1



AEB1



AEC1



AEC2

TOTEM - EXTENSIBLE H. 74

design Studio Sovet
2000

Tavolo con due basi inox satinato o metallo laccato, varie finiture. Struttura allungabile in finitura alluminio. Top allungabile in vetro temperato, laccato, acidato laccato o placcato, vari colori.

Dining table with two mat stainless steel or lacquered metal bases, various finishes. Extensible tempered glass top lacquered, frosted lacquered or plated, various colours. Extensible structure with aluminium finish.

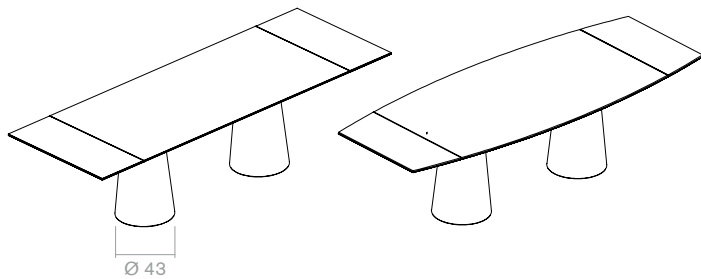

DIMENSIONS cm	TOP	BASE	COD.	M ³	KG
Close 170x90 Open 250x90	12 FL	FB/FC/FN/FT	P1618 _ _ _	0,63	210
		IX	P1618IX _ _	0,63	210
Close 200x100 Open 280x100	12 FL	FB/FC/FN/FT	P1702 _ _ _	0,69	230
		IX	P1702IX _ _	0,69	230
Close 250x100 Open 330x100	12 FL	FB/FC/FN/FT	P1704 _ _ _	0,75	260
		IX	P1704IX _ _	0,75	260
Close 200x110 Open 280x110	12 FL45°	FB/FC/FN/FT	P1706 _ _ _	0,70	230
		IX	P1706IX _ _	0,70	230

FINITURE BASE / BASE FINISHES

Acciaio Inox / Stainless steel



IX

Metallo laccato / Lacquered metal



FB FC FN FT

FINITURE TOP / TOP FINISHES

VETRO FLOAT CLEAR GLASS	VETRO EXTRACHIARO EXTRALIGHT GLASS		ACIDATO FROSTED
Lacquered Cat. A / C	Lacquered Cat. B / D	Plated Cat. P	Lacquered Cat. E
€	€	€	€
3070	3250	3860	3380
3770	3950	4560	4080
3330	3570	4330	3720
4030	4270	5030	4420
3650	3920	4820	4110
4350	4620	5520	4810
3410	3640	4440	3810
4110	4340	5140	4510

TRB2	TEA1	TEYO	AEA1
TRC1	TEB1	TEYA	AEB1
TRN1	TEC2	TEYR	AEC1
TRN2	TER2		AEC2
TRR1	TER3		
TRMP	TEV1		
TRM1	TEM4		
TRM2	TEM5		
TRM3	TES1		

TOTEM - ROUND H. 35

design Lievore Altherr Molina
2004

Tavolino con base in inox satinato o metallo laccato, varie finiture. Top in HPL (sp. 12 mm - becco d'oca) o in vetro temperato laccato, acidato laccato o decorato laccato.

Coffee table with stainless steel or lacquered metal base, various finishes. Top in HPL (th. 12 mm) or tempered glass, lacquered, frosted lacquered or decorated lacquered.

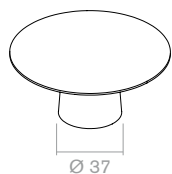

FINITURE TOP / TOP FINISHES

VETRO FLOAT	VETRO EXTRACHIARO EXTRALIGHT GLASS	ACIDATO FROSTED	CIRCLES CIRCLES	LAMINATO LAMINATE
Lacquered Cat. A / C	Lacquered Cat. B / D	Lacquered Cat. E	Circles Cat. O	Laminate Cat. HPL
€	€	€	€	€
540	560	570	560	-
680	700	710	700	-
570	600	610	650	-
710	740	750	790	-
660	710	730	-	-
800	850	870	-	-
770	850	890	-	940
910	990	1030	-	1080

DIMENSIONS cm	TOP	BASE	COD.	M ³	KG
Ø 48	10 BC / 8	FB/FC/FN/FT	P4647 _ _ _	0,09	25
		IX	P4647IX _ _	0,09	25
Ø 62	10 BC / 8	FB/FC/FN/FT	P4651 _ _ _	0,10	29
		IX	P4651IX _ _	0,10	29
Ø 80	10 BC	FB/FC/FN/FT	P4646 _ _ _	0,12	35
		IX	P4646IX _ _	0,12	35
Ø 100	10 BC	FB/FC/FN/FT	P4650 _ _ _	0,14	44
		IX	P4650IX _ _	0,14	44

FINITURE BASE / BASE FINISHES

Acciaio Inox / Stainless steel



IX

Metallo laccato / Lacquered metal



FB

FC

FN

FT

TRB2	TEA1	AEA1	O1M3	HB
TRC1	TEB1	AEB1	O1S1	HN
TRN1	TEC2	AEC1		
TRN2	TER2	AEC2		
TRR1	TER3			
TRMP	TEV1			
TRM1	TEM4			
TRM2	TEM5			
TRM3	TES1			

TOTEM - SHAPED H. 35

design Lievore Altherr Molina
2004

Tavolino con base in inox satinato o metallo laccato, varie finiture. Top in HPL (sp. 12 mm - becco d'oca) o in vetro temperato laccato, acidato laccato o decorato laccato.

Coffee table with stainless steel or lacquered metal base, various finishes. Top in HPL (th. 12 mm) or tempered glass, lacquered, frosted lacquered or decorated lacquered.

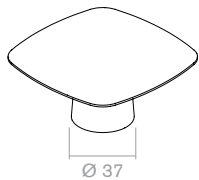

FINITURE TOP / TOP FINISHES

VETRO FLOAT	VETRO EXTRACHIARO EXTRALIGHT GLASS	ACIDATO FROSTED	CIRCLES CIRCLES	LAMINATO LAMINATE
Lacquered Cat. A / C	Lacquered Cat. B / D	Lacquered Cat. E	Circles Cat. O	Laminate Cat. HPL
€	€	€	€	€
540	560	570	560	-
680	700	710	700	-
570	600	610	650	660
710	740	750	790	800
660	710	730	-	760
800	850	870	-	900
770	850	890	-	940
910	990	1030	-	1080

FINITURE BASE / BASE FINISHES

Acciaio Inox / Stainless steel



IX

Metallo laccato / Lacquered metal



FB

FC

FN

FT

TRB2	TEA1	AEA1	01M3	HB
TRC1	TEB1	AEB1		
TRN1	TEC2	AEC1	01S1	HN
TRN2	TER2	AEC2		
TRR1	TER3			
TRMP	TEV1			
TRM1	TEM4			
TRM2	TEM5			
TRM3	TES1			

TOTEM - ROUND H. 48

design Lievore Altherr Molina
2004

Tavolino con base in inox satinato o metallo laccato, varie finiture. Top in vetro temperato laccato, acidato laccato o decorato laccato.

Coffee table with stainless steel or lacquered metal base, various finishes. Tempered glass top, lacquered, frosted lacquered or decorated lacquered.

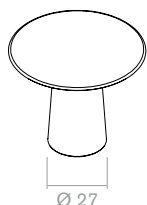

DIMENSIONS cm	TOP	BASE	COD.	M ³	KG
● Ø 48	10 BC / 8	FB/FC/FN/FT	P4643 _ _ _	0,09	26
		IX	P4643IX _ _	0,09	26
● Ø 62	10 BC / 8	FB/FC/FN/FT	P4638 _ _ _	0,10	30
		IX	P4638IX _ _	0,10	30
● Ø 80	10 BC	FB/FC/FN/FT	P4642 _ _ _	0,11	36
		IX	P4642IX _ _	0,11	36

FINITURE TOP / TOP FINISHES

VETRO FLOAT CLEAR GLASS	VETRO EXTRACHIARO EXTRALIGHT GLASS	ACIDATO FROSTED	CIRCLES CIRCLES
Lacquered Cat. A / C	Lacquered Cat. B / D	Lacquered Cat. E	Circles Cat. O
€	€	€	€
540	560	570	560
680	700	710	700
570	600	610	650
710	740	750	790
660	710	730	-
800	850	870	-

FINITURE BASE / BASE FINISHES

Acciaio Inox / Stainless steel



IX

Metallo laccato / Lacquered metal



FB

FC

FN

FT



TRB2



TRC1



TRN1



TRN2



TRR1



TRMP



TRM1



TRM2



TRM3



TEA1



TEB1



TEC2



TER2



TER3



TEV1



TEM4



TEM5



TES1



AEA1



AEB1



AEC1



AEC2



O1M3



O1S1



AEC1



AEC2

TOTEM - SHAPED H. 48

design Lievore Altherr Molina
2004

Tavolino con base in inox satinato o metallo laccato, varie finiture. Top in HPL (sp. 12 mm - becco d'oca) o in vetro temperato laccato, acidato laccato o decorato laccato.

Coffee table with stainless steel or lacquered metal base, various finishes. Top in HPL (th. 12 mm) or tempered glass, lacquered, frosted lacquered or decorated lacquered.

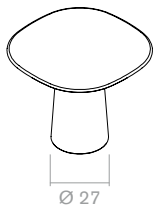

DIMENSIONS cm	TOP	BASE	COD.	M ³	KG
48x48	10 BC / 8	FB/FC/FN/FT	P4645 _ _ _	0,09	26
		IX	P4645IX _ _	0,09	26
62x62	10 BC / 8	FB/FC/FN/FT	P4640 _ _ _	0,10	30
		IX	P4640IX _ _	0,10	30
80x80	10 BC	FB/FC/FN/FT	P4644 _ _ _	0,11	37
		IX	P4644IX _ _	0,11	37

FINITURE TOP / TOP FINISHES

VETRO FLOAT	VETRO EXTRACHIARO EXTRALIGHT GLASS	ACIDATO FROSTED	CIRCLES CIRCLES	LAMINATO LAMINATE
Lacquered Cat. A / C	Lacquered Cat. B / D	Lacquered Cat. E	Circles Cat. O	Laminate Cat. HPL
€	€	€	€	€
540	560	570	560	-
680	700	710	700	-
570	600	610	650	660
710	740	750	790	800
660	710	730	-	760
800	850	870	-	900

FINITURE BASE / BASE FINISHES

Acciaio Inox / Stainless steel



IX

Metallo laccato / Lacquered metal



FB

FC

FN

FT

TRB2	TEA1	AEA1	01M3	HB
TRC1	TEB1	AEB1		
TRN1	TEC2	AEC1		HN
TRN2	TER2	AEC2	01S1	
TRR1	TER3			
TRMP	TEV1			
TRM1	TEM4			
TRM2	TEM5			
TRM3	TES1			

TOTEM WOOD - ROUND H. 35-48

design Lievore Altherr Molina
2004

Tavolino con base in inox satinato o metallo laccato, varie finiture.
Piano in multistrato di legno di betulla finlandese spessore 26 mm,
con bordo a vista tagliato a 45°, impiallacciato noce oppure rovere
sia in finitura spazzolata che taglio a sega.



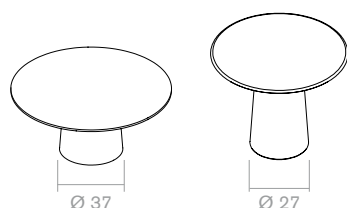

Coffee table with stainless steel or lacquered metal base, various finishes. Multi-layer Finnish birch wood top 26mm. thickness, 45°-cut edge, walnut or oak veneered, brushed or saw cut finish.



DIMENSIONS cm	TOP	BASE	COD.	M ³
● Ø 48x35h	26	FB/FC/FN/FT	P4647 _ _ _	0,09
		IX	P4647IX _ _	0,09
● Ø 48x48h	26	FB/FC/FN/FT	P4643 _ _ _	0,09
		IX	P4643IX _ _	0,09
● Ø 62x35h	26	FB/FC/FN/FT	P4651 _ _ _	0,10
		IX	P4651IX _ _	0,10
● Ø 62x48h	26	FB/FC/FN/FT	P4638 _ _ _	0,10
		IX	P4638IX _ _	0,10

FINITURE TOP / TOP FINISHES

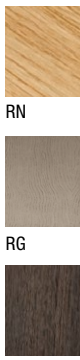
LEGNO WOOD		
NOCE Canaletto Canaletto WALNUT	ROVERE OAK	ROVERE taglio sega saw cut OAK
€	€	€
600	600	610
740	740	750
600	600	610
740	740	750
650	650	660
790	790	800
650	650	660
790	790	800

FINITURE BASE / BASE FINISHES			
<p>Acciaio Inox / Stainless steel</p>  <p>IX</p> <p>Metallo laccato / Lacquered metal</p>  <p>FB FC FN FT</p>	 <p>NC</p>	 <p>RN</p> <p>RG</p> <p>WG</p>	 <p>R5</p> <p>R6</p> <p>R7</p>

VALENCIA - H. 74

design Lievore Altherr Molina
2006

Tavolo con base in vetro curvo trasparente o trasparente extrachiario con parte a terra laccata, varie finiture.
Top in vetro temperato trasparente, trasparente extrachiario, laccato, acidato laccato o placcato, varie finiture.

*Dining table with clear or extralight bent glass base and leaning part lacquered, various finishes.
Tempered glass top clear or extralight, lacquered, frosted lacquered or plated, various finishes.*

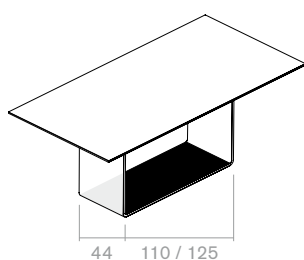

FINITURE TOP / TOP FINISHES

VETRO FLOAT CLEAR GLASS		VETRO EXTRACHIARIO EXTRALIGHT GLASS			ACIDATO FROSTED
Clear TRTR	Lacquered Cat. A/C	Extralight TETE	Lacquered Cat. B/D	Plated Cat. P	Lacquered Cat. E
€	€	€	€	€	€
-	-	2040	2310	3170	2510
-	-	2320	2660	3700	2910
1630	1900	-	-	-	-
1830	2170	-	-	-	-

Base in vetro trasparente extrachiario con parte a terra B/D/Z
Extralight glass base with leaning part B/D/P/Z

DIMENSIONS cm	TOP	COD.	M ³	KG
200x100	15 FL Temp.	P1530TE _ TE _	0,60	144
250x100	15 FL Temp.	P1532TE _ TE _	0,69	170

Base in vetro trasparente con parte a terra A/C
Clear glass base with leaning part A/C

DIMENSIONS cm	TOP	COD.	M ³	KG
200x100	15 FL Temp.	P1530TR _ TR _	0,60	144
250x100	15 FL Temp.	P1532TR _ TR _	0,69	170

FINITURE PARTE A TERRA / LEANING PART FINISHES

Cat. A



Cat. B



Cat. C



Cat. D



Cat. Z



TRTR

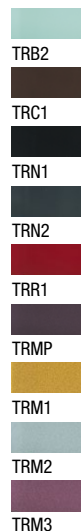

TETE



VALENCIA - EXTENSIBLE H. 74

design Lievore Altherr Molina
2006

Tavolo con base in vetro curvo trasparente o trasparente extrachiaro con parte a terra laccata, varie finiture.
Struttura allungabile con finitura alluminio. Top allungabile in vetro temperato laccato, acidato laccato o placcato, varie finiture.

Dining table with clear or extralight bent glass base and leaning part lacquered, various finishes. Extensible tempered glass top lacquered, frosted lacquered or plated, various finishes. Extensible structure with aluminium finish.

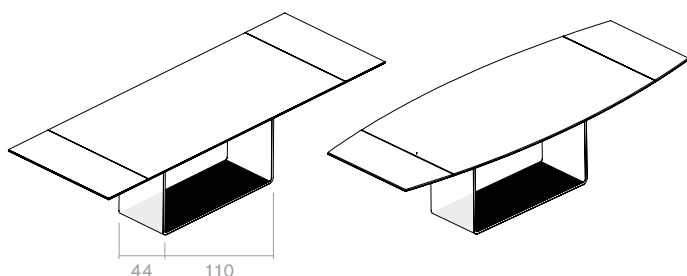

DIMENSIONS cm	TOP	COD.	M ³	KG
Base in vetro trasparente extrachiaro con parte a terra B/D/Z Extralight glass base with leaning part B/D/P/Z				
Close 170x90 Open 250x90	12 FL Temp.	P1538TE _ TE _	0,73	176
Close 200x100 Open 280x100	12 FL Temp.	P1537TE _ TE _	0,79	200
Close 200x110 Open 280x110	12 FL Temp.	P1535TE _ TE _	0,80	199
Base in vetro trasparente con parte a terra A/C Clear glass base with leaning part A/C				
Close 170x90 Open 250x90	12 FL Temp.	P1538TR _ TR _	0,73	176
Close 200x100 Open 280x100	12 FL Temp.	P1537TR _ TR _	0,79	200
Close 200x110 Open 280x110	12 FL Temp.	P1535TE _ TR _	0,80	199

FINITURE TOP / TOP FINISHES

VETRO FLOAT CLEAR GLASS	VETRO EXTRACHIAIRO EXTRALIGHT GLASS		ACIDATO FROSTED
Lacquered Cat. A/C	Lacquered Cat. B/D	Plated Cat. P	Lacquered Cat. E
€	€	€	€
-	3400	4260	3530
-	3720	4730	3880
-	3840	4880	4010
3020	-	-	-
3290	-	-	-
3410	-	-	-

FINITURE PARTE A TERRA / LEANING PART FINISHES

Cat. A					
TRB2	TRC1	TRN1	TRN2	TRR1	TRMP
Cat. B					
TEA1	TEB1	TEC2	TER2	TER3	TEV1
Cat. C			Cat. D		
TRM1	TRM2	TRM3	TEM4	TEM5	TES1
Cat. Z					
TEC1	TEN1	TEN2	TER1	TEM3	TEMP

TRB2	TEA1	TEYO	AEA1
TRC1	TEB1	TEYA	AEB1
TRN1	TEC2	TEYR	AEC1
TRN2	TER2		AEC2
TRR1	TER3		
TRMP	TEV1		
TRM1	TEM4		
TRM2	TEM5		
TRM3	TES1		

3FEET

design Gianluigi Landoni
2009

Tavolino esagonale disponibile nella versione trasparente, trasparente extrachiario o laccato mono e bicolore. Disponibile anche nella versione decorata con motivi a strisce o fiori.

Hexagonal coffee table in bent glass clear, extralight or lacquered mono or two-tones. Available also in the decorated version with stripes or flowers pattern.

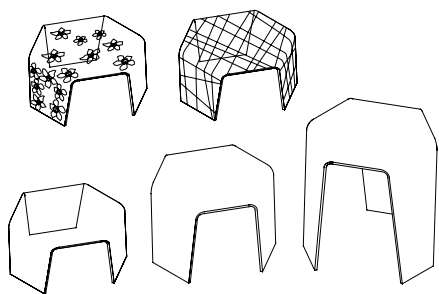

DIMENSIONS cm	SP. / TH.	BASE	COD.	M ³	KG	FINITURE TOP / TOP FINISHES					
						VETRO FLOAT CLEAR GLASS			VETRO EXTRACHIARO EXTRALIGHT GLASS		
						Clear TRTR	Lacquered Cat. A	Two-tones Cat. A or C	Extralight TETE	Lacquered Cat. B	Two-tones Cat. B or D
						€	€	€	€	€	€
62x62x33	10		P4680 _ _	0,22	20	370	550	580	460	640	670
62x62x33	10	Con motivo a strisce Stripes pattern	P4684 _ _	0,22	20	500	680	-	600	780	-
62x62x33	10	Con motivo floreale Flowers pattern	P4686 _ _	0,22	20	500	680	-	600	780	-
62x62x48	10		P4688 _ _	0,29	24	510	710	740	660	860	890
62x62x73	10		P4690 _ _	0,45	30	800	1020	1060	960	1180	1220



TRTR

TRB2



TRC1



TRN1



TRN2



TRR1



TRMP



TRB2



TRC1



TRN1



TRN2



TRR1



TRMP



TRM1 *



TRM2 *



TRM3 *



TETE

TEA1



TEB1



TEC2



TER2



TER3



TEV1



TEA1 *



TEB1



TEC2



TER2



TER3



TEV1



TEM4 *

TEM5 *

TES1 *

* I colori contrassegnati possono essere utilizzati solo per il lato esterno e devono essere sempre protetti internamente da un secondo colore.

* The marked colours can only be used on the external side and need to be protected by a second internal colour.

GENIUS - SHAPED

design Gianluigi Landoni
2012

Tavolino con base in metallo cromo lucido e piano in vetro temperato trasparente, trasparente extrachiaro, decorato floreale o laccato, varie finiture. Disponibile in varie altezze e dimensioni.

Coffee table with polished chrome metal base and clear, extralight, decorated with flowers pattern or lacquered tempered glass top, various finishes. Available in different heights and sizes.

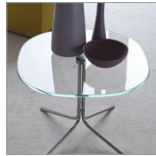
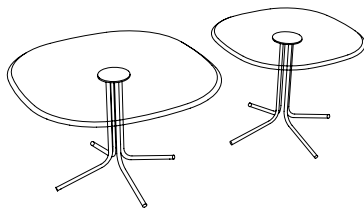

FINITURE TOP / TOP FINISHES

DIMENSIONS cm	TOP	COD.	M ³	KG	VETRO FLOAT CLEAR GLASS		VETRO EXTRACHIARO EXTRALIGHT GLASS		ACIDATO FROSTED	CIRCLES CIRCLES	LAMINATO LAMINATE
					Clear TRTR	Lacquered Cat. A / C	Extralight TETE	Lacquered Cat. B / D	Cat. E / AEAE	Circles Cat. O	Laminate Cat. HPL
					€	€	€	€	€		€
48x48x38h	8/10 BC Temp.	P4716LC _ _	0,03	9	300	340	330	360	370	360	-
62x62x38h	8/10 BC Temp.	P4718LC _ _	0,05	13	340	380	370	410	430	460	490
48x48x45h	8/10 BC Temp.	P4720LC _ _	0,03	9	315	355	345	375	385	380	-
62x62x45h	8/10 BC Temp.	P4722LC _ _	0,05	13	355	395	385	425	445	480	505
48x48x60h	8/10 BC Temp.	P4724LC _ _	0,04	10	330	370	360	390	400	390	-
62x62x60h	8/10 BC Temp.	P4726LC _ _	0,05	14	370	410	400	440	460	490	520

FINITURE BASE / BASE FINISHES

Cromo lucido / Polished chrome



LC

Metallo laccato / Lacquered metal



FC



TRTR

TRB2
TRC1
TRN1
TRN2
TRR1
TRMP
TRM1
TRM2
TRM3



TETE

TEA1
TEB1
TEC2
TER2
TER3
TEV1
TEM4
TEM5
TES1

AEA1
AEB1
AEC1
AEC2
AEAE



O1M3



O1S1



HB



HN

GENIUS - ROUND

design Gianluigi Landoni
2012

Tavolino con base in metallo cromo lucido e piano in vetro temperato trasparente, trasparente extrachiario, decorato floreale o laccato, varie finiture. Disponibile in varie altezze e dimensioni.

Coffee table with polished chrome metal base and clear, extralight, decorated with flowers pattern or lacquered tempered glass top, various finishes. Available in different heights and sizes.

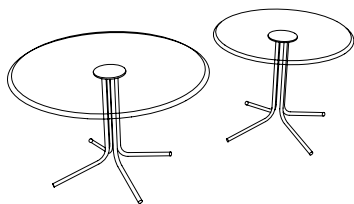

DIMENSIONS cm	TOP	COD.	M ³	KG
∅ 48x38h	8/10 BC Temp.	P4700LC _ _	0,03	8
∅ 62x38h	8/10 BC Temp.	P4702LC _ _	0,05	13
∅ 48x45h	8/10 BC Temp.	P4704LC _ _	0,03	9
∅ 62x45h	8/10 BC Temp.	P4706LC _ _	0,05	13
∅ 48x60h	8/10 BC Temp.	P4708LC _ _	0,04	10
∅ 62x60h	8/10 BC Temp.	P4710LC _ _	0,05	14

FINITURE TOP / TOP FINISHES

VETRO FLOAT CLEAR GLASS		VETRO EXTRACHIARO EXTRALIGHT GLASS		ACIDATO FROSTED	CIRCLES CIRCLES
Clear TRTR	Lacquered Cat. A / C	Extralight TETE	Lacquered Cat. B / D	Cat. E / AEAE	Circles Cat. O
€	€	€	€	€	
300	340	330	360	370	360
340	380	370	410	430	460
315	355	345	375	385	380
355	395	385	425	445	480
330	370	360	390	400	390
370	410	400	440	460	490

FINITURE BASE / BASE FINISHES

Cromo lucido / Polished chrome



LC

Metallo laccato / Lacquered metal



FC

	<ul style="list-style-type: none"> TRB2 TRC1 TRN1 TRN2 TRR1 TRMP TRM1 TRM2 TRM3 		<ul style="list-style-type: none"> TEA1 TEB1 TEC2 TER2 TER3 TEV1 TEM4 TEM5 TES1 	<ul style="list-style-type: none"> AEA1 AEB1 AEC1 AEC2 AEAE 	<ul style="list-style-type: none">  O1M3  O1S1
---	--	---	--	--	--

GENIUS WOOD - ROUND

design Gianluigi Landoni
2012

Tavolino con base in metallo cromo lucido o laccato caffè. Disponibile nelle versioni con piano in multistrato di legno di betulla finlandese spessore 26 mm.

Coffee table with polished chrome or mocha lacquered metal base. Available with multi-layer Finnish birch wood top 26mm.

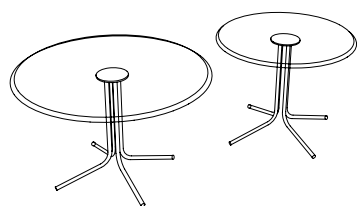

FINITURE TOP / TOP FINISHES

DIMENSIONS cm	TOP	COD.	M ³	LEGNO WOOD		
				NOCE Canaletto Canaletto WALNUT	ROVERE OAK	ROVERE taglio sega saw cut OAK
				€	€	€
Ø 48x38h	26	P4700 _ _	0,03	455	455	470
Ø 62x38h	26	P4702 _ _	0,05	515	515	530
Ø 48x45h	26	P4704 _ _	0,03	470	470	480
Ø 62x45h	26	P4706 _ _	0,05	530	530	540
Ø 48x60h	26	P4708 _ _	0,04	485	485	500
Ø 62x60h	26	P4710 _ _	0,05	545	545	555

FINITURE BASE / BASE FINISHES

Cromo lucido / Polished chrome



LC

Metallo laccato / Lacquered metal



FC



NC



RN



R5



RG



R6



WG



R7

HUG

design Massimo Zaniboni & Paola Bonazzi
2013

Tavolino in vetro curvo trasparente extrachiario.
Parte a terra laccata con pannello in mdf incollato,
sp. 18 mm.

Extralight bent glass coffee table.
Lacquered leaning part with 18 mm. th. glued mdf panel.

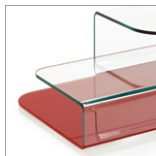
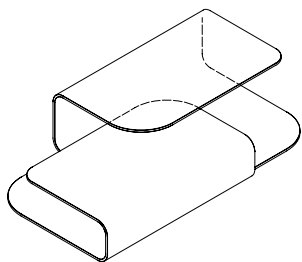

DIMENSIONS cm	SP. / TH.	COD.	M ³	KG
138x72x34h	15	P4050 __	0,47	86

FINITURE TOP / TOP FINISHES

VETRO EXTRACHIARO EXTRALIGHT GLASS

Extralight TETE	Plated Cat. P
€	€
2000	2400



TETE

CON BASE / WITH BASE

Cat. B	Cat. D	Cat. Z	
TEA1	TEM4	TEC1	TEYO
TEB1	TEM5	TEN1	
TEC2	TES1	TEN2	
TER2		TER1	TEYR
TER3		TEM3	
TEV1		TEMP	

NIDO

design Lievore Altherr Molina
2002

Tavolino con struttura in cromo lucido.
Top in vetro curvato trasparente, trasparente
extrachiaro placcato o laccato, mono o bicolore.

*Coffee table with polished chrome structure
and clear, extraclear, plated or lacquered mono
or two-tones glass top.*

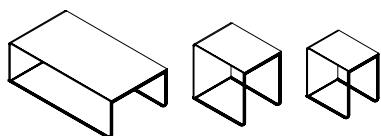

DIMENSIONS cm	SP. / TH.	COD.	M ³	KG
45x33x46h	10	P4570LC _ _	0,10	11
55x40x52h	10	P4572LC _ _	0,15	15
110x60x36h	12	P4574LC _ _	0,32	34
110x60x30h	12	P4576LC _ _	0,32	34
130x69x36h	12	P4578LC _ _	0,43	44

Cromo lucido / Polished chrome



LC

FINITURE TOP / TOP FINISHES

VETRO FLOAT CLEAR GLASS			VETRO EXTRACHIARO EXTRALIGHT GLASS			
Clear TRTR	Lacquered Cat. A	Two-tones Cat. A or C	Extralight TETE	Lacquered Cat. B	Two-tones Cat. B or D	Plated Cat. P
€	€	€	€	€	€	€
300	350	370	320	370	390	480
320	380	400	360	420	430	540
510	650	680	560	690	730	960
500	630	670	550	680	710	940
640	820	870	710	880	930	1240



TRTR

TRB2

TRC1

TRN1

TRN2

TRR1

TRMP

TRB2

TRC1

TRN1

TRN2

TRR1

TRMP

TRM1 *

TRM2 *

TRM3 *



TETE

TEA1

TEB1

TEC2

TER2

TER3

TEV1

TEA1 *

TEB1

TEC2

TER2

TER3

TEV1

TEM4 *

TEM5 *

TES1 *



TEYO



TEYA



TEYR

* I colori contrassegnati possono essere utilizzati solo per il lato esterno e devono essere sempre protetti internamente da un secondo colore.

* The marked colours can only be used on the external side and need to be protected by a second internal colour.

NIDO

design Lievore Altherr Molina
2002

Console con struttura in cromo lucido.
Top in vetro curvo placcato o laccato, vari colori.

*Console with polished chrome metal structure.
Bent glass top plated or lacquered, various colours.*

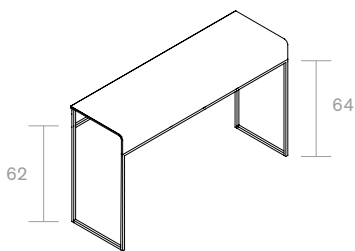

DIMENSIONS cm	SP. / TH.	BASE	COD.	M ³	KG
130x40x78h	10	LC	P5090LC _ _	0,53	34

FINITURE TOP / TOP FINISHES

VETRO FLOAT CLEAR GLASS	VETRO EXTRACHIARO EXTRALIGHT GLASS	
	Lacquered Cat. A / C	Lacquered Cat. B / D
€	€	€
900	970	1310

FINITURE STRUTTURA / STRUCTURE FINISHES

Cromo lucido / Polished chrome



LC

TRB2	TEA1	TEYO
TRC1	TEB1	TEYA
TRN1	TEC2	TEYR
TRN2	TER2	
TRR1	TER3	
TRMP	TEV1	
TRM1	TEM4	
TRM2	TEM5	
TRM3	TES1	

RING

design Gianluigi Landoni
2013

Tavolino con base in metallo laccato, varie finiture. Top in vetro trasparente extrachiaro, extrachiaro acidato o stratificato 8+8 in fumé o bronzo.

*Lacquered metal coffee table, various finishes.
Extralight clear, extralight frosted or smoky glass top. Glass top in Extraclear or frosted extraclear finish or laminated 8+8 mm smoked or bronzed.*

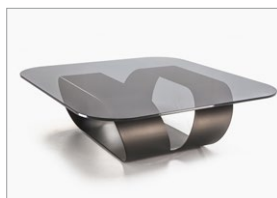
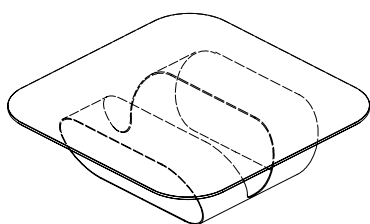

DIMENSIONS cm	TOP	BASE	COD.	M ³	KG
115x115x35h	15 FL	GB / GT / GC / GN	P4360 _ _	0,37	84
115x115x35h	8+8*	GB / GT / GC / GN	P4362 _ _	0,37	75

FINITURE TOP / TOP FINISHES

VETRO EXTRACHIARO EXTRALIGHT GLASS	FUME' / BRONZO SMOKY / BRONZED	ACIDATO FROSTED
Extralight TETE	Smoky / Bronzed TFTF / TBTB	AEAE
€	€	€
1200	-	1400
-	1309	-

FINITURE STRUTTURA / STRUCTURE FINISHES

Metallo laccato / Lacquered metal



GB GT GC GN



TETE



TFTF *



TBTB *



AEAE

* Top in vetro stratificato 8mm + 8mm

* Top in laminated glass 8mm + 8mm

RING - BASE

design Gianluigi Landoni
2013

Tavolino in metallo laccato, varie finiture.

Lacquered metal coffee table, various finishes.

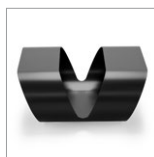
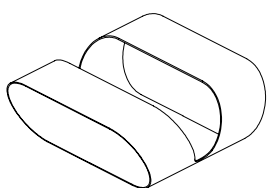

DIMENSIONS cm	BASE	COD.	M ³	KG	€
80x78x33h	GB / GT / GC / GN	P4360/BA1 _ _	0,28	43	800

FINITURE BASE / BASE FINISHES

Metallo laccato / Lacquered metal



GB GT GC GN

RUBINO

design Guido Porcellato
2002

Tavolino in vetro curvo trasparente,
trasparente extrachiario, placcato o laccato
mono o bicolore.

*Clear, extralight, plated or lacquered mono
or two-tones bent glass coffee table.*

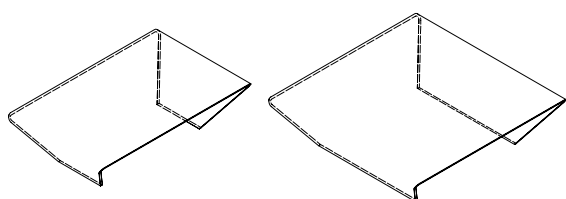

DIMENSIONS cm	SP. / TH.	GOD.	M ³	KG
110x70x29h	12	P4552 _ _	0,31	45
110x90x29h	12	P4554 _ _	0,42	54
110x110x29h	12	P4558 _ _	0,50	66

FINITURE TOP / TOP FINISHES

VETRO FLOAT CLEAR GLASS			VETRO EXTRACHIARO EXTRALIGHT GLASS			
Clear TRTR	Lacquered Cat. A	Two-tones Cat. A or C	Extralight TETE	Lacquered Cat. B	Two-tones Cat. B or D	Plated Cat. P
€	€	€	€	€	€	€
680	900	960	820	1050	1100	1500
750	1040	1110	960	1250	1320	1820
880	1240	1330	1100	1460	1550	2160



TRTR

TRB2

TRC1

TRN1

TRN2

TRR1

TRMP

TRB2

TRC1

TRN1

TRN2

TRR1

TRMP

TRM1 *

TRM2 *

TRM3 *



TETE

TEA1

TEB1

TEC2

TER2

TER3

TEV1

TEM4 *

TEM5 *

TES1 *

TEA1 *

TEB1

TEC2

TER2

TER3

TEV1

TEM4 *

TEM5 *

TES1 *



TEYO



TEYA



TEYR

* I colori contrassegnati possono essere utilizzati solo per il lato esterno e devono essere sempre protetti internamente da un secondo colore.

* The marked colours can only be used on the external side and need to be protected by a second internal colour.

TAKY

design Guido Porcellato
2013

Tavolino in vetro curvo trasparente,
trasparente extrachiario, placcato o laccato
mono o bicolore.

*Clear, extralight, plated or lacquered mono
or two-tones bent glass coffee table.*

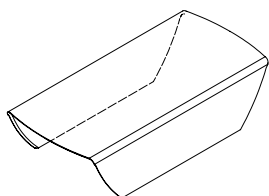

DIMENSIONS cm	SP. / TH.	COD.	M ³	KG	FINITURE TOP / TOP FINISHES							
					VETRO FLOAT CLEAR GLASS			VETRO EXTRACHIARO EXTRALIGHT GLASS				
					Clear TRTR	Lacquered Cat. A	Two-tones Cat. A or C	Extralight TETE	Lacquered Cat. B	Two-tones Cat. B or D	Plated Cat. P	
					€	€	€	€	€	€	€	
118x56x30h	12	P4190 _ _	0,27	37	580	820	880	690	940	990	1500	
140x56x30h	12	P4192 _ _	0,32	45	650	940	1010	790	1070	1140	1640	



TRTR

TRB2

TRC1

TRN1

TRN2

TRR1

TRMP

TRB2

TRC1

TRN1

TRN2

TRR1

TRMP

TRM1 *

TRM2 *

TRM3 *



TETE

TEA1

TEB1

TEC2

TER2

TER3

TEV1

TEA1 *

TEB1

TEC2

TER2

TER3

TEV1

TEM4 *

TEM5 *

TES1 *



TEYO



TEYA



TEYR

* I colori contrassegnati possono essere utilizzati solo per il lato esterno e devono essere sempre protetti internamente da un secondo colore.

* The marked colours can only be used on the external side and need to be protected by a second internal colour.

SPIDER

design Lievore Altherr Molina
2005

Tavolino in vetro curvo trasparente,
trasparente extrachiaro, placcato o laccato
mono o bicolore.

*Clear, extralight, plated or lacquered mono
or two-tones bent glass coffee table.*

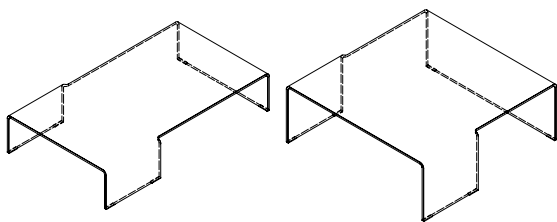

DIMENSIONS cm	SP. / TH.	COD.	M ³	KG
122x72x24h	12	P4660 _ _	0,30	41
122x72x36h	12	P4661 _ _	0,41	48
100x100x24h	12	P4665 _ _	0,34	52
100x100x36h	12	P4666 _ _	0,48	56

FINITURE TOP / TOP FINISHES

VETRO FLOAT CLEAR GLASS			VETRO EXTRACHIARO EXTRALIGHT GLASS			
Clear TRTR	Lacquered Cat. A	Two-tones Cat. A or C	Extralight TETE	Lacquered Cat. B	Two-tones Cat. B or D	Plated Cat. P
€	€	€	€	€	€	€
630	870	940	770	1020	1080	1640
800	1120	1210	980	1300	1390	2120
660	920	990	800	1070	1140	1730
760	1040	1120	940	1230	1300	1950



TRTR

	TRB2		TRB2
	TRC1		TRC1
	TRN1		TRN1
	TRN2		TRN2
	TRR1		TRR1
	TRMP		TRMP
			TRM1 *
			TRM2 *
			TRM3 *



TETE

	TEA1		TEA1 *		TEYO
	TEB1		TEB1		TEYA
	TEC2		TEC2		TEYR
	TER2		TER2		
	TER3		TER3		
	TEV1		TEV1		
			TEM4 *		
			TEM5 *		
			TES1 *		

* I colori contrassegnati possono essere utilizzati solo per il lato esterno
e devono essere sempre protetti internamente da un secondo colore.

* The marked colours can only be used on the external side and need to
be protected by a second internal colour.

SHELL- CLEAR

design Lievore Altherr Molina
2005

Tavolino in vetro curvo trasparente o trasparente extrachiaro con parte a terra laccata.

Clear or extralight bent glass coffee table with lacquered leaning part.

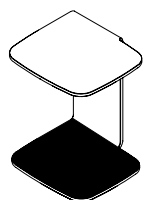

P4672

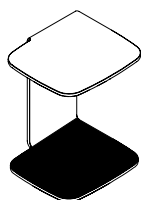

P4670



DIMENSIONS cm	SP. / TH.	COD.	M ³	KG
48x48x57h	15	P4670 __	0,16	23
48x48x57h	15	P4672 __	0,16	23



FINITURE TOP / TOP FINISHES

VETRO FLOAT CLEAR GLASS	VETRO EXTRACHIARO EXTRALIGHT GLASS
Clear TRTR	Extralight TETE
€	€
440	540
440	540



TRTR



TETE

CON BASE / WITH BASE

Cat. A

Cat. C

CON BASE / WITH BASE

Cat. B

Cat. D

Cat. Z



TRB2



TRC1



TRN1



TRN2



TRR1



TRMP



TRM1



TRM2



TRM3



TEA1



TEB1



TEC2



TER2



TER3



TEV1



TEM4



TEM5



TES1



TEC1



TEN1



TEN2



TER1



TEM3



TEMP

SHELL - COLOUR

design Lievore Altherr Molina
2005

Tavolino in vetro curvo mono o bicolore.

Bent glass coffee table mono or Two-tones.



P4676



P4674



DIMENSIONS cm	SP. / TH.	BASE	GOD.	M ³	KG
48x48x57h	15	Monocolore Monotone	P4674 _ _	0,16	23
48x48x57h	15	Monocolore Monotone	P4676 _ _	0,16	23

FINITURE TOP / TOP FINISHES

VETRO FLOAT CLEAR GLASS		VETRO EXTRACHIARO EXTRALIGHT GLASS	
Lacquered Cat. A	Two-tones Cat. A or C	Lacquered Cat. B	Two-tones Cat. B or D
€	€	€	€
490	520	600	630
490	520	600	630

	TRB2		TRB2		TEA1		TEA1 *
	TRC1		TRC1		TEB1		TEB1
	TRN1		TRN1		TEC2		TEC2
	TRN2		TRN2		TER2		TER2
	TRR1		TRR1		TER3		TER3
	TRMP		TRMP		TEV1		TEV1
			TRM1 *		TEM4 *		TEM4 *
			TRM2 *		TEM5 *		TEM5 *
			TRM3 *		TES1 *		TES1 *

* I colori contrassegnati possono essere utilizzati solo per il lato esterno e devono essere sempre protetti internamente da un secondo colore.

* The marked colours can only be used on the external side and need to be protected by a second internal colour.

SWAN - CLEAR

design Lievore Altherr Molina
2002

Tavolino in vetro curvo trasparente o
trasparente extrachiario con parte a terra laccata.
Piastra incollata in inox satinato.

*Clear or extralight bent glass coffee table with lacquered
leaning part. Glued mat stainless steel plate.*

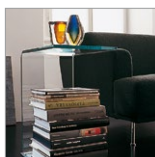
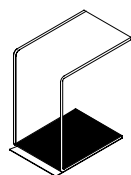

DIMENSIONS cm	SP. / TH.		COD.	M ³	KG
48x32x57h	15	Solo base laccata Lacquered bottom only	P4560/1 _ _	0,13	23

FINITURE TOP / TOP FINISHES

VETRO FLOAT CLEAR GLASS	VETRO EXTRACHIARO EXTRALIGHT GLASS
Clear TRTR	Extralight TETE
€	€
380	430



TRTR



TETE

CON BASE / WITH BASE

Cat. A

Cat. C

CON BASE / WITH BASE

Cat. B

Cat. D

Cat. Z



TRB2



TRC1



TRN1



TRN2



TRR1



TRMP



TRM1



TRM2



TRM3



TEA1



TEB1



TEC2



TER2



TER3



TEV1



TEM4



TEM5



TES1



TEC1



TEN1



TEN2



TER1



TEM3



TEMP

SWAN - COLOUR

design Lievore Altherr Molina
2002

Tavolino in vetro curvo acidato laccato o laccato, mono o bicolore. Piastra incollata in inox satinato.

Frosted lacquered or lacquered mono or two-tones bent glass coffee table. Glued mat stainless steel plate.

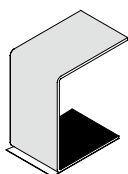

DIMENSIONS cm	SP. / TH.	BASE	COD.	M ³	KG
48x32x57h	15	Monocolore Monotone	P4560 _ _	0,13	23
48x32x57h	15	Bicolore Two-tones	P4561 _ _	0,13	23

FINITURE TOP / TOP FINISHES

VETRO FLOAT CLEAR GLASS		VETRO EXTRACHIARO EXTRALIGHT GLASS		ACIDATO FROSTED
Lacquered Cat. A	Two-tones Cat. A or C	Lacquered Cat. B	Two-tones Cat. B or D	Lacquered Cat. E
€	€	€	€	€
410	-	460	-	600
-	430	-	480	-

<p>TRB2</p> <p>TRC1</p> <p>TRN1</p> <p>TRN2</p> <p>TRR1</p> <p>TRMP</p>	<p>TRB2</p> <p>TRC1</p> <p>TRN1</p> <p>TRN2</p> <p>TRR1</p> <p>TRMP</p> <p>TRM1 *</p> <p>TRM2 *</p> <p>TRM3 *</p>	<p>TEA1</p> <p>TEB1</p> <p>TEC2</p> <p>TER2</p> <p>TER3</p> <p>TEV1</p> <p>TEV1</p> <p>TEM4 *</p> <p>TEM5 *</p> <p>TES1 *</p>	<p>TEA1 *</p> <p>TEB1</p> <p>TEC2</p> <p>TER2</p> <p>TER3</p> <p>TEV1</p> <p>TEM4 *</p> <p>TEM5 *</p> <p>TES1 *</p>	<p>AEA1</p> <p>AEB1</p> <p>AEC1</p> <p>AEC2</p>
---	---	---	---	---

* I colori contrassegnati possono essere utilizzati solo per il lato esterno e devono essere sempre protetti internamente da un secondo colore.

* The marked colours can only be used on the external side and need to be protected by a second internal colour.

TULIP - ROUND

design Guido Porcellato
2005

Tavolino con base in metallo cromato o laccato, varie finiture.
Top in vetro temperato trasparente, acidato o decorato.
Disponibile anche nella versione laccata, vari colori e finiture.

Coffee table with chromed or lacquered metal base, various finishes. Available also in the lacquered version, various colours and finishes.

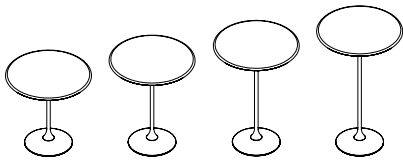

DIMENSIONS cm	TOP	BASE	COD.	M ³	KG
Ø 48x46h	10 BC / 8	LC/FB/FN/FC	P4600 _ _ _	0,03	15
Ø 62x46h	10 BC / 8	LC/FB/FN/FC	P4604 _ _ _	0,04	19
Ø 48x56h	10 BC / 8	LC/FB/FN/FC	P4608 _ _ _	0,03	15
Ø 62x56h	10 BC / 8	LC/FB/FN/FC	P4612 _ _ _	0,04	19
Ø 48x66h	10 BC / 8	LC/FB/FN/FC	P4616 _ _ _	0,03	15
Ø 62x66h	10 BC / 8	LC/FB/FN/FC	P4620 _ _ _	0,04	19
Ø 48x76h	10 BC / 8	LC/FB/FN/FC	P4624 _ _ _	0,03	16
Ø 48x86h	10 BC / 8	LC/FB/FN/FC	P4626 _ _ _	0,03	16

FINITURE BASE / BASE FINISHES

Cromo lucido / Polished chrome



LC

Metallo laccato / Lacquered metal

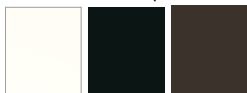

FB

FN

FC

FINITURE TOP / TOP FINISHES

VETRO FLOAT CLEAR GLASS		VETRO EXTRACHIARO EXTRALIGHT GLASS		ACIDATO FROSTED	CIRCLES CIRCLES
Clear TRTR	Lacquered Cat. A / C	Extralight TETE/TFTF/TBTB	Lacquered Cat. B / D	Cat. E / H AEAE	Circles Cat. O
€	€	€	€	€	€
330	380	350	410	420	410
350	420	380	450	460	490
340	390	360	420	430	420
360	430	390	460	470	500
350	400	370	430	440	430
370	440	400	470	480	510
360	410	380	440	450	440
370	420	390	450	460	450

TRTR	TRC1	TETE	TEB1	AEB1	O1M3
	TRN1		TEC2	AEC1	
	TRN2	TFTF	TER2	AEC2	O1S1
	TRR1		TER3		
	TRMP	TBTB	TEV1		
	TRM1		TEM4		
	TRM2		TEM5		
	TRM3		TES1		

TULIP - SHAPED

design Guido Porcellato
2005

Tavolino con base in metallo cromato o laccato, varie finiture.
Top in vetro temperato trasparente, acidato o decorato.
Disponibile anche nella versione laccata, vari colori e finiture.

Coffee table with chromed or white lacquered metal base, various finishes. Available also in the lacquered version, various colours and finishes.

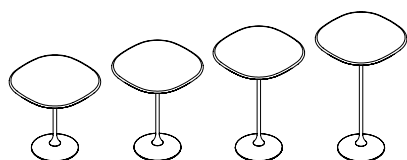

DIMENSIONS cm	TOP	BASE	COD.	M ³	KG
48x48x46h	10 BC / 8	LC/FB/FN/FC	P4602 _ _ _	0,03	15
62x62x46h	10 BC / 8	LC/FB/FN/FC	P4606 _ _ _	0,04	19
48x48x56h	10 BC / 8	LC/FB/FN/FC	P4610 _ _ _	0,03	15
62x62x56h	10 BC / 8	LC/FB/FN/FC	P4614 _ _ _	0,04	19
48x48x66h	10 BC / 8	LC/FB/FN/FC	P4618 _ _ _	0,03	16
62x62x66h	10 BC / 8	LC/FB/FN/FC	P4622 _ _ _	0,04	20
48x48x76h	10 BC / 8	LC/FB/FN/FC	P4625 _ _ _	0,03	16
48x48x86h	10 BC / 8	LC/FB/FN/FC	P4627 _ _ _	0,03	16

FINITURE TOP / TOP FINISHES

VETRO FLOAT CLEAR GLASS		VETRO EXTRACHIARO EXTRALIGHT GLASS		ACIDATO FROSTED	CIRCLES CIRCLES
Clear TRTR	Lacquered Cat. A / C	Extralight TETE/TTF/TBTB	Lacquered Cat. B / D	Cat. E / H AEAE	Circles Cat. O
€	€	€	€	€	€
330	380	350	410	420	410
350	420	380	450	460	490
340	390	360	420	430	420
360	430	390	460	470	500
350	400	370	430	440	430
370	440	400	470	480	510
360	410	380	440	450	440
370	420	390	450	460	450

FINITURE BASE / BASE FINISHES

Cromo lucido / Polished chrome



LC

Metallo laccato / Lacquered metal

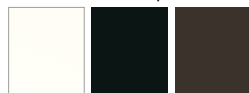

FB

FN

FC



TRTR



TRC1



TRN1



TRN2



TRR1



TRMP



TRM1



TRM2

TRM3



TETE



TTF



TBTB



TEA1



TEB1



TEC2



TER2



TER3



TEV1



TEM4

TEM5

TES1



AEA1



AEB1



AEC1



AEC2



O1M3



O1S1

TULIP WOOD - ROUND

design Guido Porcellato
2005

Tavolino con base in metallo cromato o laccato, varie finiture.
Disponibile nelle versioni con piano in multistrato di legno di
betulla finlandese spessore 26 mm.

*Coffee/lamp table with polished chrome or lacquered metal
base, various finishes. Multi-layer Finnish birch wood top
26mm. thickness.*

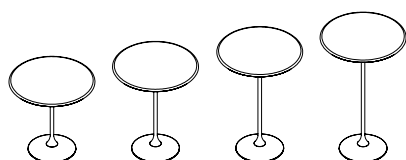

DIMENSIONS cm	TOP	BASE	GOD.	M ³
Ø 48x46h	26	LC/FB/FN/FC	P4600 _ _ _	0,03
Ø 62x46h	26	LC/FB/FN/FC	P4604 _ _ _	0,04
Ø 48x56h	26	LC/FB/FN/FC	P4608 _ _ _	0,03
Ø 62x56h	26	LC/FB/FN/FC	P4612 _ _ _	0,04
Ø 48x66h	26	LC/FB/FN/FC	P4616 _ _ _	0,03
Ø 62x66h	26	LC/FB/FN/FC	P4620 _ _ _	0,04
Ø 48x76h	26	LC/FB/FN/FC	P4624 _ _ _	0,03
Ø 48x86h	26	LC/FB/FN/FC	P4626 _ _ _	0,03

FINITURE BASE / BASE FINISHES

Cromo lucido / Polished chrome



LC

Metallo laccato / Lacquered metal



FB

FN

FC

FINITURE TOP / TOP FINISHES

LEGNO WOOD		
NOCE Canaletto Canaletto WALNUT	ROVERE OAK	ROVERE taglio sega saw cut OAK
€	€	€
500	500	510
550	550	560
510	510	520
560	560	570
520	520	530
570	570	580
530	530	540
540	540	550

 NC	 RN	 R5
	 RG	 R6
	 WG	 R7

BOSTON

design Studio Sovet
2000

Specchiera da attacco verticale o orizzontale disponibile
in varie dimensioni, anche su misura al centimetro.

*Horizontal / vertical hanging mirror.
Available in different sizes, also custom-made.*

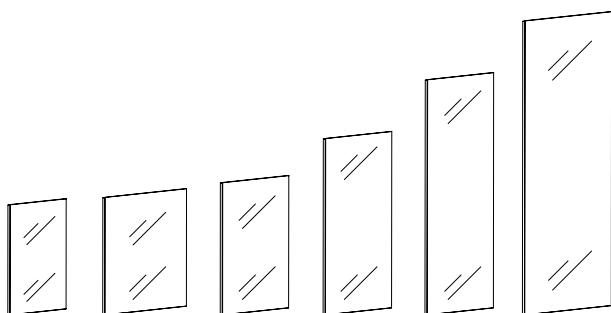

DIMENSIONS cm	SP. / TH.	COD.	M ³	KG	€	
75x55	25	P5061 _ _ _	0,03	9	160	
80x80	25	P5060 _ _ _	0,04	11	200	
90x65	25	P5062 _ _ _	0,04	10	190	
120x65	25	P5064 _ _ _	0,05	12	240	
160x65	25	P5065 _ _ _	0,07	16	290	
200x85	25	P5066 _ _ _	0,12	26	390	



SESP



SFSP



SBSP

BOSTON - COLOUR

design Studio Sovet
2000

Specchiera da attacco verticale o orizzontale con bordo laccato sul retro, vari colori, oppure sabbato frontalmente nella versione SA.

Horizontal / vertical hanging mirror with lacquered frame on the back, various colours, or sanded on the front side in the version SA.

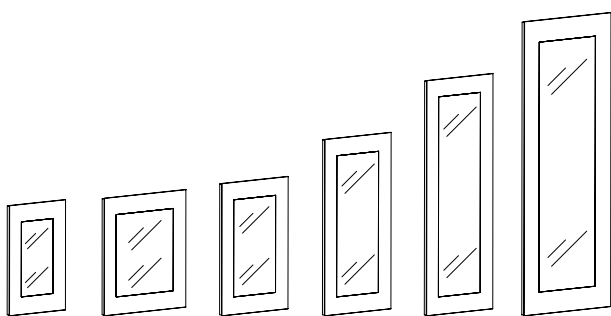

DIMENSIONS cm	SP. / TH.	COD.	M ³	KG
75x55	25	P5061 _ _ _	0,03	9
80x80	25	P5060 _ _ _	0,04	11
90x65	25	P5062 _ _ _	0,04	10
120x65	25	P5064 _ _ _	0,05	12
160x65	25	P5065 _ _ _	0,07	16
200x85	25	P5066 _ _ _	0,12	26

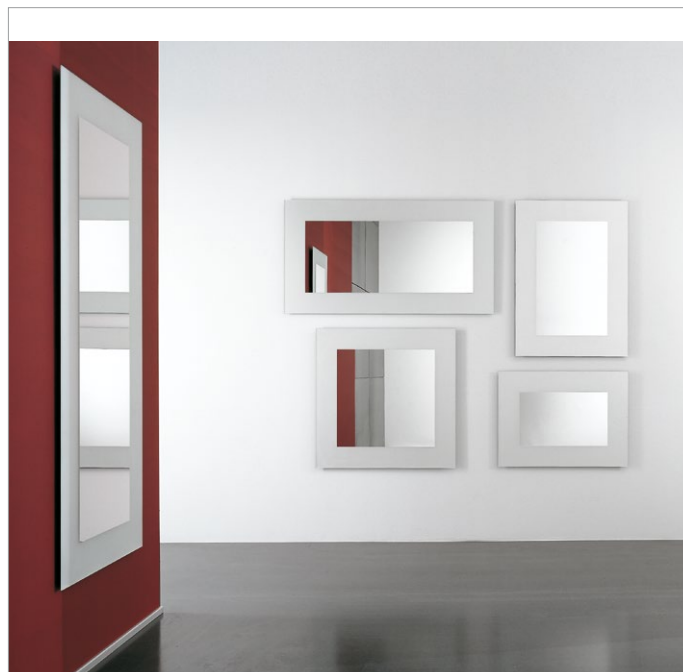

FINITURE CORNICE / FRAME FINISHES

Frosted mirror SEAC/SFAC/SBAC	Lacquered Cat. A / C	Lacquered Cat. B / D
€	€	€
200	220	240
270	340	380
260	320	350
330	410	450
410	520	570
590	770	860

 STSA SFAC SBAC	 TRB2 TRC1 TRN1 TRN2 TRR1 TRMP TRM1 TRM2 TRM3	 TEA1 TEB1 TEC2 TER2 TER3 TEV1 TEM4 TEM5 TES1
----------------------------------	--	--

DENVER FRAME 16

design Guido Porcellato
2002

Specchiera con telaio in alluminio per attacco verticale / orizzontale o con appoggio a terra. Cornice perimetrale disponibile in vari colori e finiture. Per la nuova versione Circles le colorazioni disponibili sono: specchiato, champagne e melanzana metallizzato. Optional: retroilluminazione a led.

Floor or horizontal / vertical hanging mirror with aluminium structure. Frame available in various colours and finishes. For the new version "Circles" the finishes available are: mirrored, champagne and metallized aubergine. Available also with led lighting on the back.

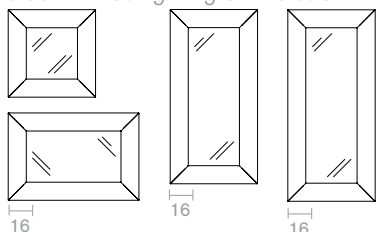

FINITURE CORNICE / FRAME FINISHES

DIMENSIONS cm	SP. / TH.	COD.	M ³	KG	Mirror	Lacquered	Lacquered	Lacquered	Decorated	Circles	Plated
					STSA / STSP / SFSP / SBSP	Cat. A / C	Cat. B / D	Cat. E	Cat. F / G	CAT. O	Cat. P
					€	€	€	€	€	€	€
90x90	70	P5352 _	0,12	24	450	490	500	520	540	580	670
90x90 *	Con luce a led With led lighting	P5352L _	0,12	24	600	640	650	670	690	730	820
120x120	70	P5353 _	0,20	40	650	710	720	740	770	820	960
120x120 *	Con luce a led With led lighting	P5353L _	0,20	40	850	910	920	940	970	1020	1160
120x90	70	P5354 _	0,15	32	540	590	600	620	640	690	810
120x90 *	Con luce a led With led lighting	P5354L _	0,15	32	720	770	780	800	820	870	990
160x90	70	P5356 _	0,20	40	650	710	720	740	770	820	960
160x90 *	Con luce a led With led lighting	P5356L _	0,20	40	850	910	920	940	970	1020	1160
180x90	70	P5358 _	0,22	44	840	920	940	960	1000	1060	1240
180x90	Con luce a led With led lighting	P5358L _	0,22	44	1110	1190	1210	1230	1270	1330	1510
220x90	70	P5360 _	0,25	37	950	1000	1020	1050	1100	1140	1240
220x90	Con luce a led With led lighting	P5360L _	0,25	37	1200	1350	1270	1300	1350	1390	1490

* Nella versione a led, specificare se attacco verticale o orizzontale.

* In the led version, please advise if vertical or horizontal hanging.

DENVER FRAME 20

design Guido Porcellato
2002

Specchiera con telaio in alluminio per attacco verticale / orizzontale o con appoggio a terra. Cornice perimetrale disponibile in vari colori e finiture. Per la nuova versione Circles le colorazioni disponibili sono: specchiato, champagne e melanzana metallizzato. Optional: retroilluminazione a led.

Floor or horizontal / vertical hanging mirror with aluminium structure. Frame available in various colours and finishes. For the new version "Circles" the finishes available are: mirrored, champagne and metallized aubergine. Available also with led lighting on the back.

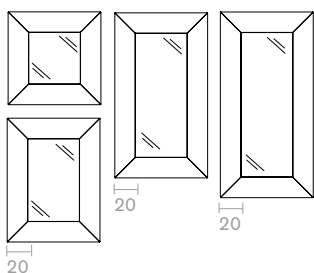

FINITURE CORNICE / FRAME FINISHES

DIMENSIONS cm	SP. / TH.	COD.	M ³	KG	Mirror STSA / STSP / SFSP / SBSP	Lacquered Cat. A / C	Lacquered Cat. B / D	Lacquered Cat. E	Decorated Cat. F / G	Circles Cat. O	Plated Cat. P
					€	€	€	€	€	€	
100x100	70	P5052 _	0,14	26	600	620	630	660	670	710	810
100x100 *	Con luce a led With led lighting	70	P5052L _	0,14	26	800	810	830	860	910	1010
150x100	70	P5054 _	0,20	37	820	840	850	890	900	960	1090
150x100 *	Con luce a led With led lighting	70	P5054L _	0,20	37	1090	1110	1130	1170	1240	1370
200x100	70	P5056 _	0,27	47	1080	1110	1130	1180	1190	1270	1430
200x100 *	Con luce a led With led lighting	70	P5056L _	0,27	47	1440	1460	1490	1530	1620	1780
220x100	70	P5057 _	0,33	62	1240	1270	1300	1350	1360	1450	1620
220x100 *	Con luce a led With led lighting	70	P5057L _	0,33	62	1600	1630	1650	1700	1800	1970
250x100	70	P5059 _	0,33	70	1600	1660	1630	1660	1710	2020	1730
250x100	Con luce a led With led lighting	70	P5059L _	0,33	70	1960	2010	1980	2010	2070	2090



* Nella versione a led, specificare se attacco verticale o orizzontale.

* In the led version, please advise if vertical or horizontal hanging.

DENVER FRAME 20







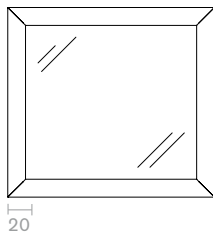

























design Guido Porcellato
2002

Specchiera con telaio in alluminio per attacco verticale / orizzontale o con appoggio a terra. Il bordo inclinato è disponibile nelle versioni specchiato, satinato, laccato, acidato laccato, decorato o placcato, varie finiture. Optional: retroilluminazione a led.

Floor or horizontal / vertical hanging mirror with aluminium structure. Sloping frame available in mirrored, sanded, lacquered, frosted lacquered, decorated or plated version, various finishes. Available also with led lighting on the back.



FINITURE CORNICE / FRAME FINISHES

DIMENSIONS cm	SP. / TH.	COD.	M ³	KG	Mirror STSP / SFSP / SBSP	Sanded STSA	Lacquered Cat. A / C	Lacquered Cat. B / D	Lacquered Cat. E	Decorated Cat. F / G	Plated Cat. P
					€	€	€	€	€	€	
240x220	70	P5058 _	0,75	120	3720	3790	3750	3790	3870	3890	4280
240x220 ★	Con luce a led With led lighting	P5058L _	0,75	120	4070	4150	4110	4150	4230	4250	4630
					 STSP  SFSP  SBSP	 STSA	 TRC1  TRN1  TRN2  TRR1  TRMP  TRM1  TRM2  TRM3	 TEA1  TEB1  TEC2  TER2  TER3  TEM4  TEM5  TES1	 AEA1  AEB1  AEC1  AEC2	 D1B1  D1C2  D1N1  D1SE  D2SE	 TEY0  TEYA  TEYR

★ Nella versione a led, specificare se attacco verticale o orizzontale.

★ In the led version, please advise if vertical or horizontal hanging.

ENDLESS

design Studio Sovet
2000

Specchiera incisa, varie dimensioni.
Disponibile anche con retroilluminazione a led.

*Engraved mirror, various sizes.
Available also with led lighting on the back.*

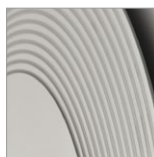
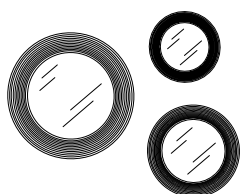
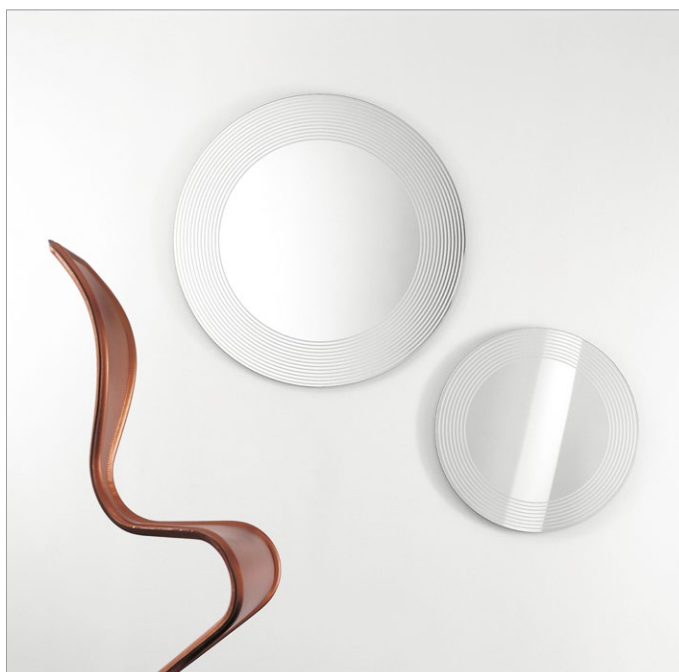

DIMENSIONS cm		SP. / TH.	COD.	M ³	KG	€	
Ø 80		30	P5016	0,04	9	270	
Ø 80	Con luce a led With led lighting	30	P5016L	0,04	10	420	
Ø 100		30	P5018	0,06	14	350	
Ø 100	Con luce a led With led lighting	30	P5018L	0,06	15	510	
Ø 140		30	P5017	0,12	24	540	
Ø 140	Con luce a led With led lighting	30	P5017L	0,12	25	740	

FIORDIVETRO

design Studio Sovet
2012

Specchiera sagomata con pannello di sostegno in metallo che permette una rotazione di 360°.

Shaped mirror with a metal panel on the back which allows a 360° rotation.

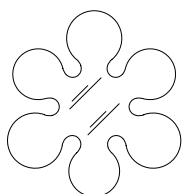

DIMENSIONS cm	SP. / TH.	COD.	M ³	KG	€	
120x128	50	P5240	0,19	18	580	

GOCCE DI RUGIADA

design Gianluigi Landoni
2009

Vetro extrachiaro spessore 15 o 6 mm sagomato, molato e retro specchiato. Disponibile in varie misure. Il particolare pannello di sostegno dello specchio permette una rotazione di 360°.

Shaped extralight glass back mirrored, th. 15 or 6 mm, polished round edge. Different sizes available. A particular panel on the back of the mirror allows a 360° rotation.

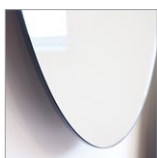
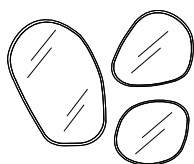

Sp. / Th. 6 mm



Sp. / Th. 15 mm

DIMENSIONS cm	SP. / TH.	COD.	M ³	KG	€
46x50	70 Specchio sp. 15 / Mirror th. 15	P5032	0,03	11	260
59x52	70 Specchio sp. 15 / Mirror th. 15	P5034	0,04	13	300
87x58	70 Specchio sp. 15 / Mirror th. 15	P5036	0,06	21	400

DIMENSIONS cm	SP. / TH.	COD.	M ³	KG	€
46x50	60 Specchio sp. 6 / Mirror th. 6	P5031	0,03	7	180
59x52	60 Specchio sp. 6 / Mirror th. 6	P5033	0,04	8	200
87x58	60 Specchio sp. 6 / Mirror th. 6	P5035	0,06	11	250

HORIZON

design Studio Sovet
2014

Specchiera con telaio in alluminio laccato caffè, creta, bianco o nero, attacco orientabile. Lo specchio centrale è disponibile nelle finiture argento, fumé o bronzo.

Mirror with mocha, clay, white or black lacquered aluminium frame, adjustable hanging. The central mirror is available in silver, smoked or bronzed finish.

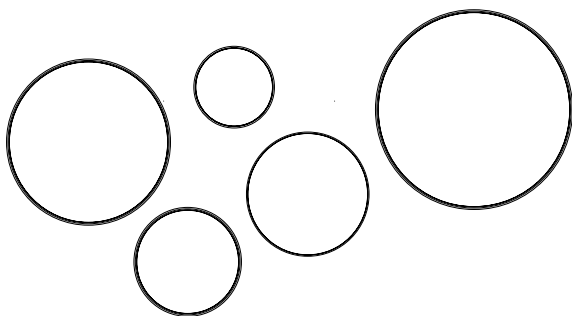

FINITURA CENTRALE / CENTRAL FINISH

DIMENSIONS cm	SP. / TH.	COD.	M ³	KG	Extralight mirror SESP	Smoked mirror SFSP	Bronzed mirror SBSP
					€	€	€
Ø 45x27	27	P5310 _	0,09	11	330	330	330
Ø 60x11	11	P5312 _	0,08	13	300	300	300
Ø 70x11	11	P5314 _	0,10	16	370	370	370
Ø 90x11	11	P5316 _	0,16	27	490	490	490
Ø 110x11	11	P5318 _	0,24	36	650	650	650

FINITURE CORNICE / FRAME FINISHES

Metallo laccato / Lacquered metal



FB FC FN FT



SESP



SFSP

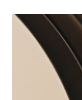

SBSP

HORIZON LINEAR

design Studio Sovet
2014

Specchiera con telaio in alluminio laccato caffè, creta, bianco o nero, attacco orientabile. Lo specchio centrale è disponibile nelle finiture argento, fumé, bronzo, ed è acidato su di un terzo della superficie. La parte acidata è realizzata per poter creare una linea dell'orizzonte armoniosa tra i vari elementi.

Mirror with mocha, clay, white or black lacquered aluminium frame, adjustable hanging. The central mirror, partially frosted, is available in silver, smoked or bronzed finish. The frosted part creates an harmonious horizon line among the different elements.

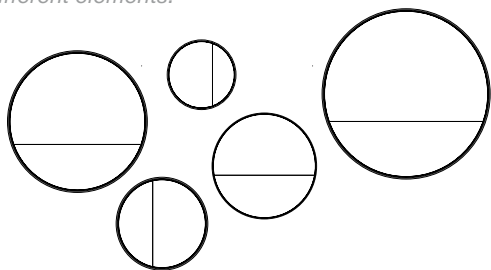

FINITURA CENTRALE / CENTRAL FINISH

DIMENSIONS cm	SP. / TH.	COD.	M ³	KG	Frosted extralight mirror SEAC	Frosted smoked mirror SFAC	Frosted bronzed mirror SBAC
					€	€	€
Ø 45x27	27	P5320 _	0,09	11	400	400	400
Ø 60x11	11	P5322 _	0,08	13	380	380	380
Ø 70x11	11	P5324 _	0,10	16	450	450	450
Ø 90x11	11	P5326 _	0,16	27	580	580	580
Ø 110x11	11	P5328 _	0,24	36	750	750	750

FINITURE CORNICE / FRAME FINISHES

Metallo laccato / Lacquered metal



FB FC FN FT



SEAC



SFAC



SBAC

ICE ROCK

design Gianluigi Landoni
2010

Specchio poligonale con bordo molato satinato.
Il particolare pannello di sostegno dello specchio
permette una rotazione di 360°.

*Polygonal mirror with bevelled sanded edge.
A particular panel on the back of the mirror allows
a 360° rotation.*

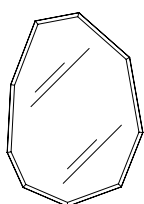

DIMENSIONS cm	SP. / TH.	COD.	M ³	KG	€	
100x70	60	P5038	0,08	13	290	
120x84	60	P5072	0,12	16	380	

LEGO

design Studio Sovet
2012

Specchiera sagomata con pannello di sostegno in metallo che permette una rotazione di 360°. La sua forma particolare permette infinite combinazioni personalizzabili.

Shaped mirror with a metal panel on the back which allows a 360° rotation. Its particular shape allows endless personal combinations.

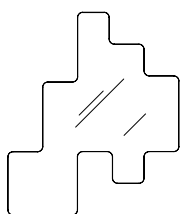

P5250

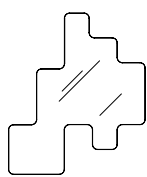

P5251

DIMENSIONS cm	SP. / TH.	COD.	M ³	KG	€	
83x98	50	P5250	0,10	13	380	
66x78	50	P5251	0,06	9	280	

MIIR SQUARE

design Studio Sovet
2014

Specchiera quadrata con struttura in alluminio. Il bordo inclinato è disponibile in vetro specchiato o laccato in vari colori e finiture. Lo specchio centrale è retrolaccato sul perimetro, vari colori disponibili, ed è sollevato rispetto alla cornice. Nella versione a led la cornice permette la rifrazione e diffusione della luce.

Square mirror with aluminium structure. The sloping frame is available in mirrored or lacquered glass, various colours and finishes. The central mirror is lacquered on the perimeter, different finishes available, and raised from the frame. In the led lighting version the frame reflects and diffuses the light.

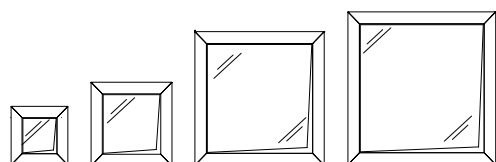
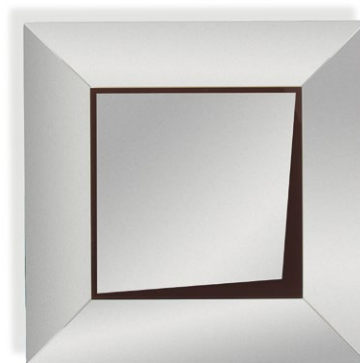

					FINITURE CORNICE / FRAME FINISHES					
					Mirror STSA / STSP / SFSP / SBSP	Lacquered Cat. A / C	Lacquered Cat. B / D	Lacquered Cat. E	Circles Cat. O	Plated Cat. P
DIMENSIONS cm	SP. / TH.	COD.	M ³	KG	€	€	€	€	€	€
90x90	65	P5282 _	0,11	25	550	580	590	600	660	710
90x90	65	P5282L _	0,11	25	690	720	730	740	800	850
120x120	65	P5283 _	0,19	35	750	790	810	830	900	1040
120x120	65	P5283L _	0,19	35	920	960	980	1000	1070	1210
140x140	65	P5284 _	0,25	50	1050	1100	1120	1150	1240	1340
140x140	65	P5284L _	0,25	50	1300	1350	1370	1400	1490	1590

FINITURA CENTRALE / CENTRAL FINISH

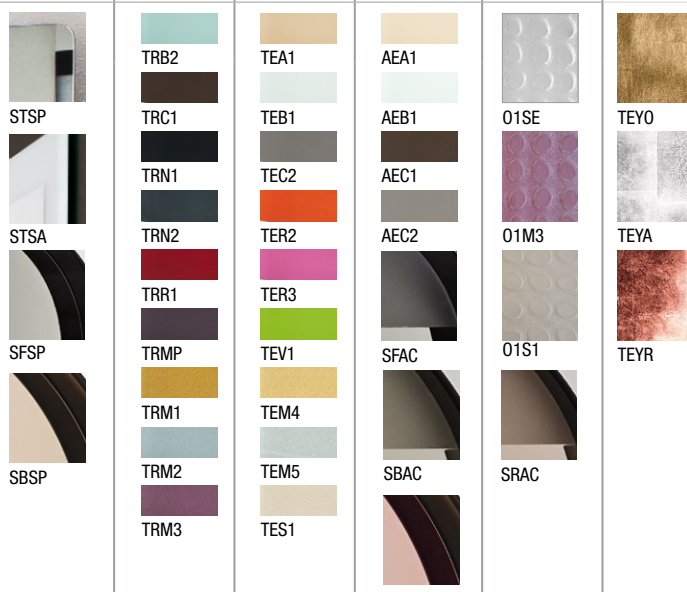

MIIR RECTANGULAR

design Studio Sovet
2014

Specchiera rettangolare con struttura in alluminio. Il bordo inclinato è disponibile in vetro specchiato o laccato in vari colori e finiture. Lo specchio centrale è retrolaccato sul perimetro, vari colori disponibili, ed è sollevato rispetto alla cornice. Nella versione a led la cornice permette la rifrazione e diffusione della luce.

Rectangular mirror with aluminium structure. The sloping frame is available in mirrored or lacquered glass, various colours and finishes. The central mirror is lacquered on the perimeter, different finishes available, and raised from the frame. In the led lighting version the frame reflects and diffuses the light.

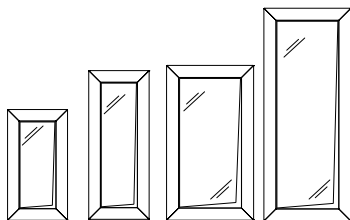

DIMENSIONS cm		SP. / TH.	COD.	M ³	KG	€	€	€	€	€	€
120x65		65	P5288 _	0,10	25	550	580	590	600	650	710
120x65	Con luce a led With led lighting	65	P5288L _	0,10	25	690	720	730	740	790	850
160x65		65	P5290 _	0,13	29	650	690	700	710	770	830
160x65	Con luce a led With led lighting	65	P5290L _	0,13	29	810	850	860	870	930	990
160x90		65	P5292 _	0,19	35	750	790	810	830	900	1040
160x90	Con luce a led With led lighting	65	P5292L _	0,19	35	920	960	980	1000	1070	1210
220x90		65	P5294 _	0,25	47	1050	1100	1120	1150	1240	1340
220x90	Con luce a led With led lighting	65	P5294L _	0,25	47	1300	1350	1370	1400	1490	1590

FINITURE CORNICE / FRAME FINISHES

Mirror STSA / STSP / SFSP / SBSP	Lacquered Cat. A / C	Lacquered Cat. B / D	Lacquered Cat. E	Circles Cat. O	Plated Cat. P

FINITURE CENTRALE / CENTRAL FINISH



SEGMENT - ROUND

design Gianluigi Landoni
2008

Specchiera con bordo segmentato inciso.
Disponibile anche con retroilluminazione a led.

*Mirror with engraved segments, various sizes.
Available also with led lighting on the back.*

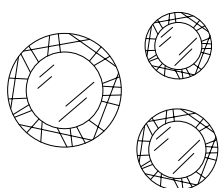

DIMENSIONS cm	SP. / TH.	COD.	M ³	KG	€	
Ø 80	30	P5086	0,04	9	280	
Ø 80	Con luce a led With led lighting	P5086L	0,04	10	440	
Ø 100	30	P5087	0,06	14	420	
Ø 100	Con luce a led With led lighting	P5087L	0,06	15	580	
Ø 140	30	P5088	0,12	24	740	
Ø 140	Con luce a led With led lighting	P5088L	0,12	25	940	

SEGMENT - RECTANGULAR

design Gianluigi Landoni
2013

Specchiera con bordo segmentato inciso.

Mirror with engraved segments, various sizes.

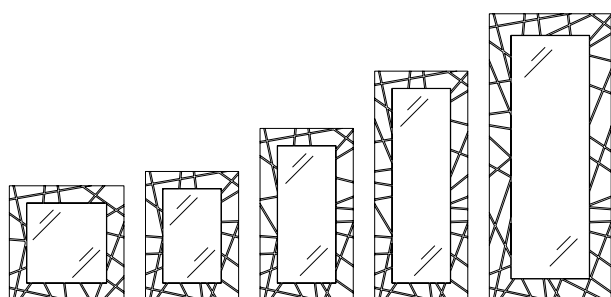

DIMENSIONS cm	SP. / TH.	COD.	M ³	KG	€	
80x80	30	P5260	0,04	11	300	
90x65	30	P5262	0,04	10	290	
120x65	30	P5264	0,05	12	360	
160x65	30	P5268	0,07	16	450	
200x85	30	P5272	0,12	26	670	

SPOT

design Studio Sovet
2000

Specchio sagomato e molato, filo lucido tondo.

Bevelled shaped mirror, polished round edge.

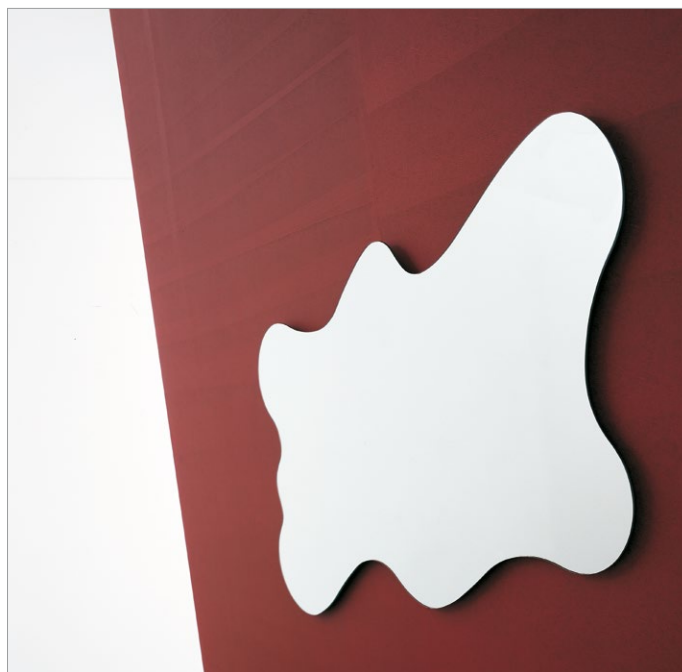

P5012

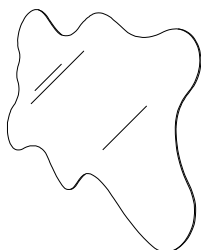

P5013

DIMENSIONS cm	SP. / TH.	COD.	M ³	KG	€	
98x53	26	P5012	0,03	9	190	
128x69	26	P5013	0,06	15	290	

VERTIGO

design Gianluigi Landoni
2008

Specchiera incisa, varie dimensioni.
Disponibile anche con retroilluminazione a led.

*Engraved mirror, various sizes.
Available also with led lighting on the back.*

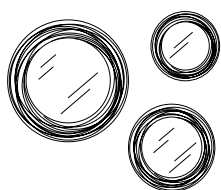
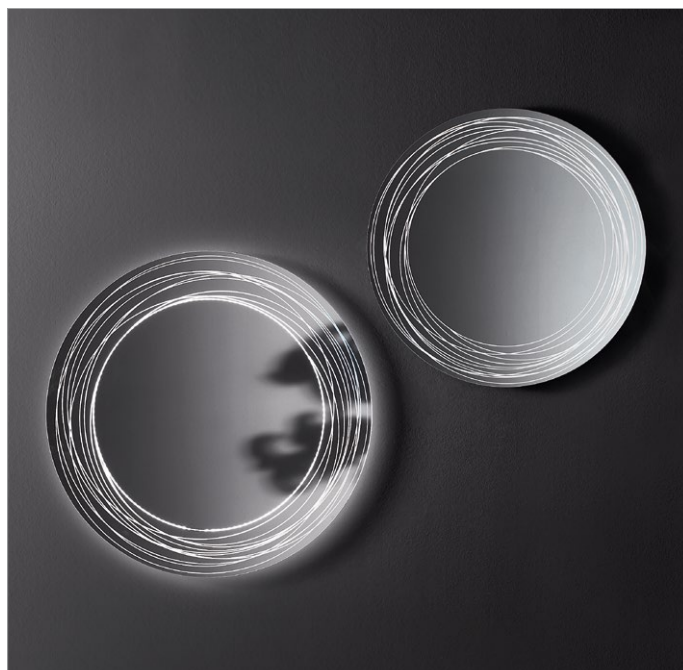

DIMENSIONS cm	SP. / TH.	COD.	M ³	KG	€	
Ø 80	30	P5080	0,04	9	270	
Ø 80	30	P5080L	0,04	10	420	
Ø 100	30	P5081	0,06	14	390	
Ø 100	30	P5081L	0,06	15	550	
Ø 140	30	P5082	0,12	24	570	
Ø 140	30	P5082L	0,12	25	770	

WAVE

design Studio Sovet
1995

Specchiera con cornice in vetro extrachiaro curvato e laccato, vari colori. Disponibile anche con retroilluminazione a led.

Mirror with bent lacquered extralight glass frame, various colours. Available also with led lighting on the back.

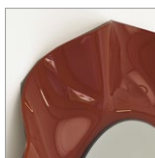
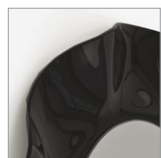

DIMENSIONS cm	SP. / TH.	COD.	M ³	KG
Ø 100	70	P5005	0,12	23
Ø 100	70	P5005L	0,12	23

Con luce a led
With led lighting

FINITURE CORNICE / FRAME FINISHES

Cat. B	Cat. D	Cat. Z
€	€	€
520	520	520
680	680	680

<p>TEA1</p> <p>TEB1</p> <p>TEC2</p> <p>TER2</p> <p>TER3</p> <p>TEV1</p>	<p>TEM4</p> <p>TEM5</p> <p>TES1</p>	<p>TEC1</p> <p>TEN1</p> <p>TEN2</p> <p>TER1</p> <p>TEM3</p> <p>TEMP</p>
---	-------------------------------------	---

TEMIRA

design Lievore Altherr Molina
2002

Specchiera da terra con struttura in acciaio
inox satinato o metallo laccato, bianco o caffè.

*Free standing floor mirror with mat stainless
steel or lacquered metal structure, white or mocha.*



DIMENSIONS cm	STRUTTURA / STRUCTURE	COD.	M ³	KG	€
43/40x182h	FB / FC	P5070 _ _ _	0,06	47	880
43/40x182h	IX	P5070IX _ _	0,06	47	1060

FINITURE STRUTTURA / STRUCTURE FINISHES

Acciaio Inox / Stainless steel



IX

Metallo laccato / Lacquered metal



FB

FC

CRICKET

design Gianluigi Landoni
2010

Console in vetro sagomato e curvato, spessore 12 mm, trasparente, trasparente extrachiaro o laccato, mono o bicolore. Cassettera in noce canaletto, bianco poro aperto o wengé.

Shaped bent glass console, th. 12 mm clear, extralight or lacquered, mono or two-tones. White opened pores, wengé or canaletto walnut drawer.

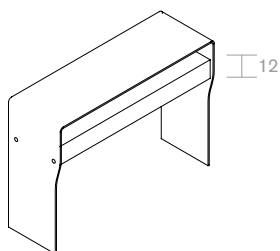

DIMENSIONS cm	SP. / TH.	COD.	M ³	KG
125x42x90h	12	P5095 _ _	0,60	69

FINITURE TOP / TOP FINISHES

VETRO FLOAT CLEAR GLASS			VETRO EXTRACHIARO EXTRALIGHT GLASS		
Clear TRTR	Lacquered Cat. A	Two-tones Cat. A or C	Extralight TETE	Lacquered Cat. B	Two-tones Cat. B or D
€	€	€	€	€	€
1460	1660	1720	1550	1760	1810

FINITURE CASSETTO / DRAWER FINISHES

Legno / Wood



WG BI NC



TRTR

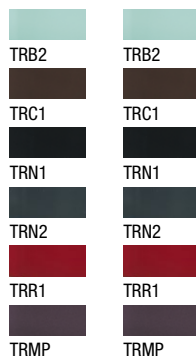

TRB2
TRC1
TRN1
TRN2
TRR1
TRMP
TRM1 *
TRM2 *
TRM3 *



TETE

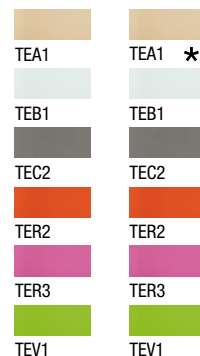

TEA1 *
TEB1
TEC2
TER2
TER3
TEV1
TEM4 *
TEM5 *
TES1 *

* I colori contrassegnati possono essere utilizzati solo per il lato esterno e devono essere sempre protetti internamente da un secondo colore.

* The marked colours can only be used on the external side and need to be protected by a second internal colour.

DELPHI - H. 190

design Studio Sovet
2010

Libreria a moduli accostabili in vetro incollato trasparente extrachiaro. Disponibile anche con schiena retrolaccata, vari colori.

*Adjoining bookcase unit in extralight glued glass.
Available also with lacquered back, various finishes.*

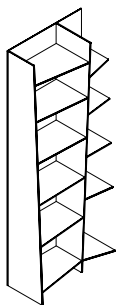

P6830

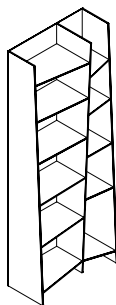

P6832



DIMENSIONS cm	SP. / TH.	COD.	M ³	KG
69x33x190h	10	P6830 __	0,73	83
70x33x190h	10	P6832 __	0,73	96

FINITURE / FINISHES

VETRO EXTRACHIARO EXTRALIGHT GLASS	VETRO EXTRACHIARO EXTRALIGHT GLASS
Extralight TETE	TETE With lacquered back
€	€
1260	1390
1420	1550



TETE



TETE

CON SCHIENA / WITH BACK

Cat. B | Cat. D | Cat. Z

TEA1	TEM4	TEC1
TEB1	TEM5	TEN1
TEC2	TES1	TEN2
TER2		TER1
TER3		TEM3
TEV1		TEMP

DELPHI - H. 96

design Studio Sovet
2012

Libreria a moduli accostabili in vetro incollato trasparente extrachiario. Disponibile anche con schiena retrolaccata, vari colori.

*Adjoining bookcase unit in extralight glued glass.
Available also with lacquered back, various finishes.*

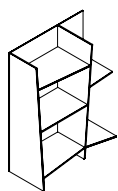

P6840

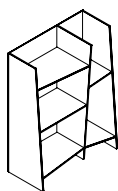

P6842

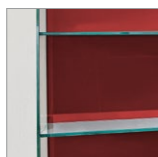

DIMENSIONS cm	SP. / TH.	COD.	M ³	KG
69x33x96h	10	P6840 __	0,31	37
70x33x96h	10	P6842 __	0,31	43

FINITURE / FINISHES

VETRO EXTRACHIARIO EXTRALIGHT GLASS	VETRO EXTRACHIARIO EXTRALIGHT GLASS
Extralight TETE	TETE With lacquered back
€	€
830	960
960	1090



TETE



TETE

CON SCHIENA / WITH BACK

Cat. B

Cat. D

Cat. Z

TEA1	TEM4	TEC1
TEB1	TEM5	TEN1
TEC2	TES1	TEN2
TER2		TER1
TER3		TEM3
TEV1		TEMP

OLYMPIA



design Studio Sovet
2000

Espositore / libreria / porta cd in vetro incollato
trasparente o trasparente extrachiaro.

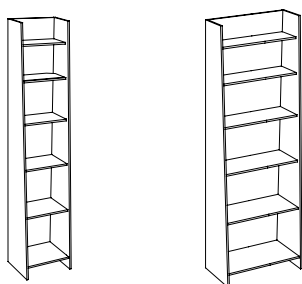
*Clear or extralight display / bookcase / cd holder
in glued glass.*



FINITURE / FINISHES

DIMENSIONS cm	SP. / TH.	COD.	M ³	KG	VETRO FLOAT CLEAR GLASS	VETRO EXTRACHIARO EXTRALIGHT GLASS
					Clear TRTR €	Extralight TETE €
36x32x180h	10	P6812	0,37	78	870	1050
60x32x180h	10	P6814	0,56	86	980	1200
					 TRTR	 TETE









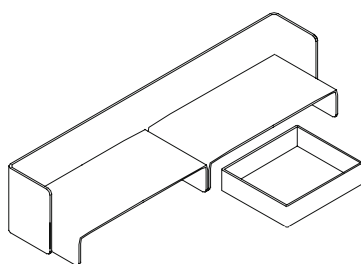











SCREEN

design Lievore Altherr Molina
2002

Composizione da soggiorno composta da due basi in vetro curvo trasparente o laccato, varie finiture. Schiena in vetro curvo extrachiaro laccato, varie finiture. Optional: cassetto in mdf laccato bianco lucido.

Living room composition consisting on two bent bases, clear or lacquered, various finishes. Extralight bent glass back, various finishes. Optional: mdf drawer lacquered polished white.



DIMENSIONS cm		TOP	COD.	M ³	KG	FINITURE / FINISHES					
						VETRO FLOAT CLEAR GLASS		VETRO EXTRACHIARO EXTRALIGHT GLASS			LEGNO WOOD
					Clear TRTR	Lacquered Cat. A	Extralight TETE	Lacquered Cat. B	Lacquered Cat. Z	LB	
					€	€	€	€	€	€	
240x35x68h	Solo schiena Back only	10	P5703 _ _	0,97	108	-	-	-	2000	2000	-
110x55x23h	Solo una base One base only	15	P5704 _ _	0,20	35	380	530	460	610	-	-
60x50x19h	Cassetto in MDF laccato Lacquered MDF drawer		P5710LB	0,10	15	-	-	-	-	-	320
						 TRTR		 TETE			 LB
						 TRB2  TRC1  TRN1  TRN2  TRR1  TRMP	 TEA1  TEB1  TEC2  TER2  TER3  TEV1	 TEC1  TEN1  TEN2  TER1  TEM3  TEMP			

TOBY

design Lievore Altherr Molina
2010

Porta TV in vetro curvato spessore 15 mm laccato, vari colori. Sostegno a terra in MDF con quattro ruote. Foro passacavi Ø 50 mm.

Lacquered TV stand in bent glass thickness 15 mm, various colours. Bottom plate in MDF with 4 wheels. Cables hole Ø 50 mm.

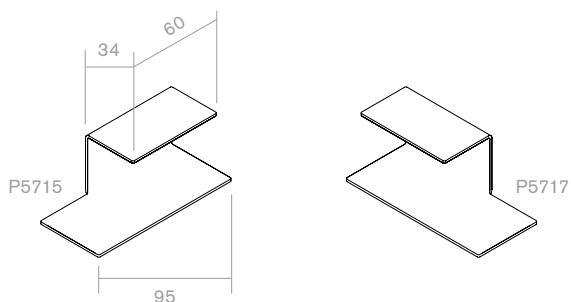

DIMENSIONS cm		SP. / TH.	COD.	M ³	KG
95x42x40h	Top lato destro Right side top	15	P5715 _ _	0,23	41
95x42x40h	Top lato sinistro Left side top	15	P5717 _ _	0,23	41

FINITURE / FINISHES

VETRO FLOAT CLEAR GLASS	VETRO EXTRACHIARO EXTRALIGHT GLASS
Lacquered Cat. A / C	Lacquered Cat. B / D
€	€
790	900
790	900

TRB2	TEA1
TRC1	TEB1
TRN1	TEC2
TRN2	TER2
TRR1	TER3
TRMP	TEV1
TRM1	TEM4
TRM2	TEM5
TRM3	TES1

DOX

design Gianluigi Landoni
2013

Portariviste in vetro curvo trasparente extrachiaro
con base in metallo laccato.

*Extralight bent glass magazine rack with
lacquered metal base.*

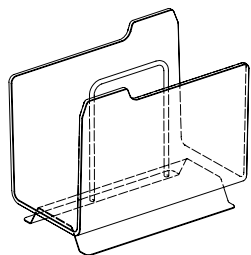

DIMENSIONS cm	SP. / TH.	BASE	COD.	M ³	KG
45x27x38h	10	FB/FN	P3610 _	0,08	11

FINITURE / FINISHES

VETRO EXTRACHIARO
EXTRALIGHT GLASS

Extralight
TETE

€

250

FINITURE STRUTTURA / STRUCTURE FINISHES

Metallo laccato / Lacquered metal



FB



FN



TETE

ZETA

design Gianluigi Landoni
2013

Portariviste in vetro curvo trasparente extrachiaro o fumé.

Extralight or smoked bent glass magazine rack.

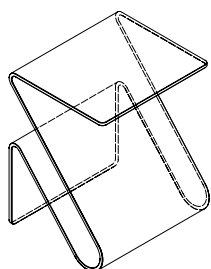

FINITURE / FINISHES

VETRO EXTRACHIARO / VETRO FUMÉ
EXTRALIGHT GLASS / SMOKED GLASS

Extralight/Smoked
TETE/TFTF

DIMENSIONS cm	SP. / TH.	COD.	M ³	KG	€
35x40x50h	12	P3620	0,11	17	450
35x60x50h	12	P3622	0,16	26	600
35x90x50h	12	P3624	0,24	39	800



TETE



TFTF

BUGATTI

design Lievore Altherr Molina
2005

Poltroncina con struttura in acciaio inox lucido o in metallo laccato. Rivestimento e cuscino in pelle "fiore" o in ecopelle, varie finiture.

Small armchair with polished stainless steel or lacquered metal structure. Body and back cushion in soft leather or fake leather, various finishes.

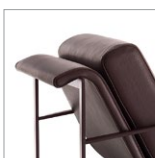
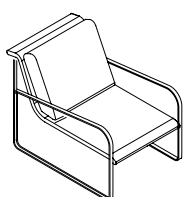

DIMENSIONS cm	STRUCTURE	COD.	M ³	KG
95x63x64h	FB/FC	P2010 _ _	0,46	21
95x63x64h	IL	P2010IL _	0,46	21

FINITURE SCOCCA / BODY FINISHES

ECOPELLE FAKE LEATHER		PELLE FIORE SOFT LEATHER	
Cat. EP		Cat. PF	
€	€	€	€
900		1300	
1200		1460	

FINITURE STRUTTURA / STRUCTURE FINISHES

Acciaio inox lucido / Polished stainless steel



IL

Metallo laccato / Lacquered metal



FB

FC



E01



E02



E03



E04



E05



E06



P50



P51



P52



P53



P54

FLÛTE - 4 LEGS

design Studio Sovet
2013

Sedia quattro gambe con struttura in metallo cromato o verniciato bianco. Scocca in polipropilene bianco. Altri colori solo su richiesta.

Four leg chair with chromed or white lacquered metal base. Polypropylene structure coloured white. Other colours are available upon request.

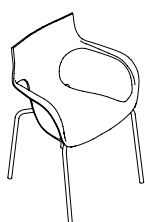

DIMENSIONS cm	STRUCTURE	COD.	M ³	KG
61x50x82h	FB	P2160FB _	0,06	7
61x50x82h	LC	P2160LC _	0,06	7

FINITURE SCOCCA / BODY FINISHES

POLIPROPILENE
POLYPROPYLENE

Cat. J

€

130

140



J01

FINITURE STRUTTURA / STRUCTURE FINISHES

Cromo lucido / Polished chrome



LC

Metallo laccato / Lacquered metal



FB

ORDINE MINIMO 4 PEZZI
Volume scatola per 4 pezzi 0,25 m³.
Peso totale 28 Kg/scatola.

*MINIMUM ORDER QUANTITY 4 PIECES
Volume box for 4 pieces 0,25 m³.
Box total weight 28 Kg/box.*

FLÛTE GIREVOLE

design Studio Sovet
2009

Sedia girevole con braccioli. Struttura in metallo cromato o laccato bianco o nero. Scocca in polipropilene bianco o nero. Seduta rivestita in ecopelle, finitura bianco o nero.

Swivel chair with arms. Chromed, white or black lacquered metal base. White or black polypropylene structure. Seat in fake leather, white or black.

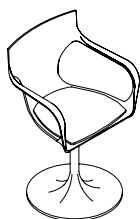

DIMENSIONS cm	STRUCTURE	COD.	M ³	KG
61x50x82h	FB/FN	P2150FB _ _ _	0,15	12
61x50x82h	LC	P2150LC _ _ _	0,15	12

FINITURE SCOCCA / BODY FINISHES

POLIPROPILENE
POLYPROPYLENE

Cat. J

€

270

300



J01

J02

FINITURE STRUTTURA / STRUCTURE FINISHES

Cromo lucido / Polished chrome



LC

Metallo laccato / Lacquered metal

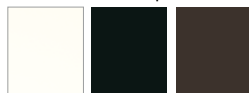

FB

FN

FC

IMBALLO

Scatola con scocche: quantità per scatola 4 pz. - volume scatola 0,20 m³.
Scatola con base: quantità per scatola 1 pz. - volume scatola 0,09 m³.

PACKING

Box with bodies: quantity per each box 4 pcs. - volume of the box 0,20 m³.
Box with the base: quantity per each box 1 pc. - volume of the box 0,09 m³.

FINITURE SEDUTA / SEAT FINISHES

Cat. EP

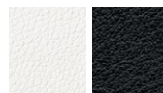

E01

E04

GLOVE GIREVOLE

design Studio Sovet
2010

Sedia girevole con base in metallo cromato o laccato bianco. Scocca rivestita in cuoio, pelle "fiore" o ecopelle, varie finiture. Disponibile anche con rivestimento trapuntato.

Swivel chair with chromed metal or white lacquered metal base. Body covered in soft leather, hard leather or fake leather, various finishes. Available with quilted covering too.

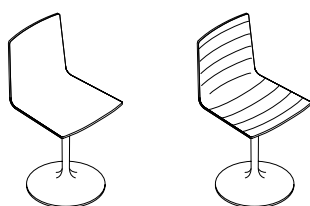

DIMENSIONS cm	STRUCTURE	COD.	M ³	KG
56x47x82h	LC	P2115LC _	0,13	12
56x47x82h	LC <small>Rivestimento trapuntato Quilted covering</small>	P2120LC _	0,13	12
56x47x82h	FB	P2115FB _	0,13	12
56x47x82h	FB <small>Rivestimento trapuntato Quilted covering</small>	P2120FB _	0,13	12

FINITURE SCOCCA / BODY FINISHES

CUOIO LEATHER	ECOPELLE FAKE LEATHER	PELLE FIORE SOFT LEATHER
Cat. CU	Cat. EP	Cat. PF
€	€	€
440	440	490
-	460	580
400	400	450
-	420	540

FINITURE STRUTTURA / STRUCTURE FINISHES

Cromo lucido / Polished chrome



LC

Metallo laccato / Lacquered metal



FB

IMBALLO

Scatola con scocche: quantità per scatola 4 pz. - volume scatola 0,14 m³.
Scatola con base: quantità per scatola 1 pz. - volume scatola 0,09 m³.

PACKING

Box with bodies: quantity per each box 4 pcs. - volume of the box 0,14 m³.
Box with the base: quantity per each box 1 pc. - volume of the box 0,09 m³.



C11



C12



C08



C05



C07



C14



E01



E02



E03



E04



E05



E06



P50



P51



P52



P53



P54

GLOVE

design Studio Sovet
2010

Sedia con struttura in acciaio inox satinato o in metallo cromato o laccato bianco. Scocca rivestita in pelle "fiore", cuoio o ecopelle, varie finiture. Disponibile anche con rivestimento trapuntato.

Chair with mat stainless steel, chromed or white lacquered metal base. Structure available in soft leather, hard leather or fake leather, various finishes. Available with quilted covering too.



DIMENSIONS cm	STRUCTURE	GOD.	M ³	KG
50x55x80h	FB Rivestimento Covering	P2111FB _	0,17	7
50x55x80h	FB Rivestimento trapuntato Quilted covering	P2112FB _	0,17	7
50x55x80h	LC Rivestimento Covering	P2111LC _	0,17	7
50x55x80h	LC Rivestimento trapuntato Quilted covering	P2112LC _	0,17	7
50x55x80h	IX Rivestimento Covering	P2111IX _	0,17	7
50x55x80h	IX Rivestimento trapuntato Quilted covering	P2112IX _	0,17	7

FINITURE SCOCCA / BODY FINISHES

CUOIO LEATHER	ECOPELLE FAKE LEATHER	PELLE FIORE SOFT LEATHER
Cat. CU	Cat. EP	Cat. PF
€	€	€
340	340	390
-	360	480
340	340	390
-	360	480
340	340	390
-	360	480

FINITURE STRUTTURA / STRUCTURE FINISHES

Cromo lucido / Polished chrome



LC

Inox satinato / Stainless steel



IX

Metallo laccato / Lacquered metal



















FB

ORDINE MINIMO 2 PEZZI

Volume scatola per 2 pezzi 0,34 m³.
Peso totale 15 Kg/scatola.

MINIMUM ORDER QUANTITY 2 PIECES

Volume box for 2 pieces 0,34 m³.
Box total weight 15 Kg/box.

		
C11	E01	P50
		
C12	E02	P51
		
C08	E03	P52
		
C05	E04	P53
		
C07	E05	P54
		
C14	E06	

SILLA

design Lievore Altherr Molina
2005

Sedia con struttura a slitta in cromo lucido. Rivestimento in pelle "fiore", cuoio o in ecopelle, varie finiture.

Polished chrome chair with sled structure, covered in soft leather, hard leather or fake leather, various finishes.

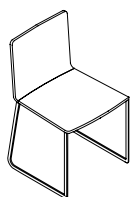

DIMENSIONS cm	STRUCTURE	COD.	M ³	KG
48x50x81h		P2090LC _	0,16	8
48x50x81h	Rivestimento trapuntato Quilted covering	P2091LC _	0,16	8

FINITURE SCOCCA / BODY FINISHES		
CUOIO LEATHER	ECOPELLE FAKE LEATHER	PELLE FIORE SOFT LEATHER
Cat. CU	Cat. EP	Cat. PF
€	€	€
410	410	460
-	430	540

FINITURE STRUTTURA / STRUCTURE FINISHES

Cromo lucido / Polished chrome



LC

ORDINE MINIMO 2 PEZZI
Volume scatola per 2 pezzi 0,32 m³.
Peso totale 16 Kg/scatola.

*MINIMUM ORDER QUANTITY 2 PIECES
Volume box for 2 pieces 0,32 m³.
Box total weight 16 Kg/box.*

C11	E01	P50
C12	E02	P51
C08	E03	P52
C05	E04	P53
C07	E05	P54
C14	E06	

SILLA - WITH ARMS

design Lievore Altherr Molina
2005

Sedia con braccioli. Struttura a slitta in cromo lucido.
Rivestimento in pelle "fiore", cuoio o in ecopelle, varie finiture.

Chair with arms. Sled structure in polished chrome. Covering in soft leather, hard leather or fake leather, various finishes.

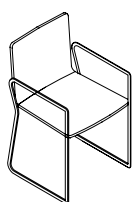

DIMENSIONS cm	STRUCTURE	GOD.	M ³	KG
54x50x81h		P2095LC _	0,27	9
54x50x81h	Rivestimento trapuntato Quilted covering	P2096LC _	0,27	9

FINITURE SCOCCA / BODY FINISHES		
CUOIO LEATHER	ECOPELLE FAKE LEATHER	PELLE FIORE SOFT LEATHER
Cat. CU	Cat. EP	Cat. PF
€	€	€
410	410	460
-	430	550

FINITURE STRUTTURA / STRUCTURE FINISHES

Cromo lucido / Polished chrome



LC

C11	E01	P50
C12	E02	P51
C08	E03	P52
C05	E04	P53
C07	E05	P54
C14	E06	

SILLA - 4 LEGS

design Lievore Altherr Molina
2005

Sedia con struttura in tubo ovale, finitura cromo lucido.
Rivestimento in cuoio, pelle "fiore" o ecopelle, varie finiture.
Disponibile anche con rivestimento trapuntato.

*Chair with structure in oval pipe in polished chrome steel.
Covering in soft leather, hard leather or fake leather, various
finishes. Available with quilted covering too.*

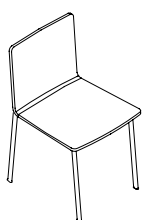

DIMENSIONS cm	STRUCTURE	COD.	M ³	KG
48x50x81h		P2080LC _	0,16	7
48x50x81h	Rivestimento trapuntato Quilted covering	P2081LC _	0,16	7

FINITURE SCOCCA / BODY FINISHES		
CUOIO LEATHER	ECOPELLE FAKE LEATHER	PELLE FIORE SOFT LEATHER
Cat. CU	Cat. EP	Cat. PF
€	€	€
390	390	440
-	410	520

FINITURE STRUTTURA / STRUCTURE FINISHES

Cromo lucido / Polished chrome



LC

ORDINE MINIMO 2 PEZZI
Volume scatola per 2 pezzi 0,32 m³.
Peso totale 15 Kg/scatola.

MINIMUM ORDER QUANTITY 2 PIECES
Volume box for 2 pieces 0,32 m³.
Box total weight 15 Kg/box.



C11



C12



C08



C05



C07



C14



E01



E02



E03



E04



E05



E06



P50



P51



P52



P53



P54

TOTEM - STOOL H. 74 / 48

design Studio Sovet
2013

Sgabello alto o basso con struttura in inox satinato o in metallo laccato, vari colori. Seduta in ecopelle, vari colori.

High or low stool with stainless steel structure or in lacquered metal, various colours. Seat in fake leather, various colours.

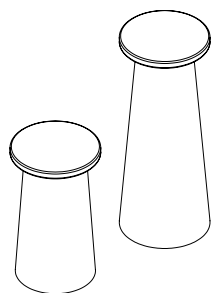

DIMENSIONS cm	BASE	COD.	M ³	KG
Ø 30x74h	FB/FC/FN/FT	P2250 _ _	0,10	14
Ø 30x74h	IX	P2250IX _	0,10	14
Ø 30x48h	FB/FC/FN/FT	P2255 _ _	0,07	11
Ø 30x48h	IX	P2255IX _	0,07	11

FINITURE SEDUTA / SEAT FINISHES

ECOPELLE
FAKE LEATHER

Cat. EP

€

300

400

250

340

FINITURE BASE / BASE FINISHES

Acciaio Inox / Stainless steel



IX

Metallo laccato / Lacquered metal



FB

FC

FN

FT



E01



E02



E03



E04



E05



Le laccature utilizzate non presentano problemi di durata: basta evitare graffi e urti contro oggetti particolarmente duri e spigolosi. Il vetro è colorato solo sulla faccia posteriore sia nei vetri laccati coprenti mono e bicolore che nei vetri acidati laccati. La tonalità dei campioni proposti è indicativa e non va pertanto intesa in senso restrittivo; può infatti differire leggermente in conformità ai margini di tolleranza riconosciuti per i materiali impiegati. I materiali impiegati possono essere puliti tranquillamente solo con acqua oppure con un detergente neutro. Evitare l'uso di abrasivi, acidi o reagenti chimici. Il vetro è interpretato attraverso la sua trasparenza, pertanto la conformità al campione può differire a seconda della superficie e degli spessori impiegati. Un esempio lampante è dato dal vetro extrachiaro che nei campioncini si presenta completamente neutro ma che nei piani di dimensioni maggiori e con spessori più consistenti assume sfumature azzurro/verdi. Per tale ragione vi preghiamo anche di segnalare con particolare attenzione articoli che debbano essere affiancati o facenti parte di una stessa commissione.

La finitura bicolore consiste nella doppia laccatura nella parte interna della lastra di vetro. La prima laccatura, visibile attraverso la trasparenza del vetro, è disponibile nelle categorie A-B-C-D. La seconda laccatura, visibile internamente, equivale al colore pastello opaco utilizzato per ottenere le finiture di cat. A-B. Vi facciamo presente che in questo caso l'effetto finale differisce da quello creato dalla medesima laccatura attraverso il vetro, in particolare nei colori tenui.

The lacquer used for our furnitures is extremely durable as long as you avoid scratching it or bumping particularly hard/sharp objects against it. The glass is lacquered on the back side only both for the mono or two-tones lacquered glasses and for the frosted lacquered. The shade of the samples is only indicative and has not to be taken as restrictive. It can infact slightly differ in conformity to the tollerances recognized for the materials used. All the materials we used can be easily cleaned with water only or with a mild detergent. Do not use abrasive materials, acids or harsh chemicals. The glass is interpreted through its transparency. Therefore the conformity to the sample might differ according to the surface and the thickness used. To give you a clear example, the extralight glass is completely neutral in the small samples but it assumes a light blue/ greenish shade when used on bigger or thicker tops. For this reason we beg you to indicate carefully those articles which have to be placed side by side or which are part of a same commission.

Two-tones finish consists of a double lacquering on the internal part of the glass sheet. The first lacquering, which is visible through the transparency of the glass, is available in the finishes of cat. A-B-C-D. The second lacquering, which is visible internally, is the same of the mat pastel used to get the finishes of cat. A-B. Please be informed that the final effect is different from the one created by the same lacquering through the glass, particularly in soft colours.

Les laques utilisées ne présentent pas de problèmes de durée. Il faut seulement éviter les rayures et les chocs avec tout objet particulièrement dur ou pointu. Le verre est laqué uniquement sur sa face postérieure (dessous) avec une laque opaque soit mono ou bicolore laissant l'aspect d'un verre translucide dessus. Les tonalités des échantillons fournis sont seulement et toujours indicatives, ne peuvent et ne doivent être considérée de manière restrictive. Elles peuvent aussi différer selon les matériaux utilisée. Les matériaux utilisés peuvent être nettoyés en toute sécurité en utilisant uniquement de l'eau ou un détergeant neutre. Ne jamais utiliser de produits abrasifs ou de réactifs chimiques. Le rendu visuel du verre et de ses tonalités dépendent de sa transparence (verre normal ou extra light) et de son épaisseur. Pour exemple celui du verre qui est totalement neutre des échantillons (extra clair) il prendra une coloration bleu/vert plus ou moins foncée selon l'importance des ses dimensions et de son épaisseur. Veuillez informer vos clients de ces particularités et suivantes.

La finition laquée bi colore consiste en un double revêtement de laque superposé sur la face interne de la plaque de verre. Le premier coloris est celui visible au travers de la transparence du verre (le dessus). Il est disponible dans las catégories A-B-C-D. Le deuxième coloris est visible à l'intérieur (dessous), il est de tonalité Pastel mat et disponible dans les finitions des catégories A-B. Veuillez noter que le résultat final diffère légèrement de celui du même coloris (mono color) visible à travers le verre (dessus), en particulier pour les coloris pastels.

El acabado lacado es de larga duración, basta con evitar arañazos y golpes con objetos muy duros y angulosos. El cristal se laca únicamente por la parte inferior, ya sea mono color, bicolor o esmerillado lacado. La tonalidad de las muestras es indicativa por lo tanto podría haber variaciones debido a los márgenes de tolerancia convenidos y aceptados para los materiales empleados. Los materiales empleados pueden ser limpiados con agua o con un detergente neutro. Evitar la utilización de abrasivos, ácidos o reactivos químicos. El cristal está interpretado en base a su transparencia, por lo tanto la tonalidad de la muestra puede ser diferente al producto final en función a las medidas y espesores empleados. Un ejemplo muy claro es el cristal extraclaro que en la muestra aparece completamente transparente pero en las tapas de medidas y espesores mas grandes tiene un matiz azul/verde. Por este motivo rogamos nos señalen los artículos que deben estar arrimados o que forman parte de la misma comisión.

El acabado bicolor es un doble laqueado en la parte interior de la pieza de cristal. La primera laca, visible a través del cristal, está disponible en las categorías A-B-C-D. La segunda laca, visible internamente, es el mismo color pastel mate utilizado para obtener los acabados de cat. A-B. Les hacemos presente que en este caso el efecto final es diferente de aquello creado por la misma laca a través del cristal, en particular en los colores tenues.

FINITURE VETRI GLASS FINISHES



COD. TRTR
TRASPARENTE
CLEAR



COD. TETE
EXTRACHIARO
EXTRALIGHT



AEAE
ACIDATO
FROSTED



TFTF
VETRO FUMÉ
SMOKED GLASS



TBTB
VETRO BRONZO
BRONZED GLASS

CAT. A

Vetro laccato / Lacquered glass



COD. TRB2
ACQUAMARINA
AQUAMARINE



COD. TRC1
CAFFÈ
MOCHA



COD. TRN1
NERO
BLACK



COD. TRN2
ANTRACITE
ANTHRACITE



COD. TRR1
ROSSO
RED



COD. TRMP
MELANZANA
PASTELLO
PASTEL AUBERGINE

CAT. B

Vetro laccato TE
Lacquered TE glass



COD. TEA1
AVORIO
IVORY



COD. TEB1
BIANCO LATTE
MILKY WHITE



COD. TEC2
CRETA
CLAY



COD. TER2
ARANCIONE
ORANGE



COD. TER3
FUCSIA
PINK



COD. TEV1
VERDE FLUO
GREEN FLUO

CAT. C

Vetro laccato metallizzato bicolore
Metallized two-tones lacquered glass



COD. TRM1
ORO
GOLD



COD. TRM2
ALLUMINIO
ALUMINIUM



COD. TRM3
MELANZANA
AUBERGINE



COD. TEM4
ORO EXTRACHIARO
EXTRALIGHT GOLD



COD. TEM5
ALLUMINIO
EXTRACHIARO
EXTRALIGHT
ALUMINIUM



COD. TES1
CHAMPAGNE
CHAMPAGNE

CAT. D

Vetro laccato metallizzato bicolore TE /
Metallized two-tones lacquered TE glass

CAT. E

Vetro TE acidato e laccato
Lacquered frosted TE glass



COD. AEA1
AVORIO ACIDATO
FROSTED IVORY



COD. AEB1
BIANCO ACIDATO
FROSTED WHITE



COD. AEC1
CAFFÈ ACIDATO
FROSTED MOCHA



COD. AEC2
CRETA ACIDATO
FROSTED CLAY

VETRI CON FINITURE SPECIALI GLASS WITH SPECIAL FINISHES

CAT. F

Vetro laccato TE decorato
Decorated lacquered TE glass

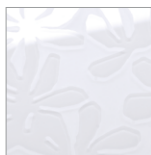

COD. D1B1
DECORO FIORI-
BIANCO
FLOWER PATTERN-
WHITE



COD. D1C2
DECORO FIORI-
CRETA
FLOWER PATTERN-
CLAY

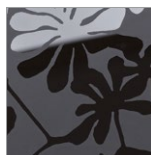

COD. D1N1
DECORO FIORI-
NERO
FLOWER PATTERN-
BLACK

CAT. G

Specchio decorato
Decorated mirror

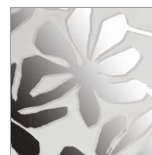

COD. D1SE
DECORO FIORI-
SPECCHIO
FLOWER PATTERN-
MIRROR

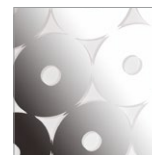

COD. D2SE
DECORO CERCHI-
SPECCHIO
CIRCLE PATTERN-
MIRROR

CAT. H

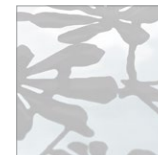

COD. D1TE
DECORO FIORI-
EXTRACHIARO
FLOWER PATTERN-
EXTRALIGHT

CAT. P

Vetro TE placcato
Plated TE glass



COD. TEYO
FOGLIA ORO
GOLD LEAF

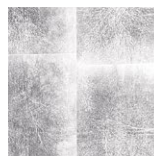

COD. TEYA
FOGLIA ARGENTO
SILVER LEAF



COD. TEYR
FOGLIA RAME
COPPER LEAF

CAT. O

Vetro Circles
Circles Glass

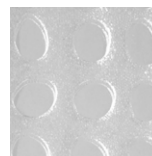

COD. O1SE
SPECCHIATO
MIRRORED



COD. O1M3
TINTA MELANZANA
LACQUERED
AUBERGINE



COD. O1S1
TINTA CHAMPAGNE
LACQUERED
CHAMPAGNE

CAT. Z

Vetro TE laccato con finitura categoria A
TE glass lacquered with finishes category A



COD. TEC1
CAFFÈ
MOCHA



COD. TEN1
NERO
BLACK



COD. TEN2
ANTRACITE
ANTHRACITE



COD. TER1
ROSSO
RED



COD. TEM3
MELANZANA
AUBERGINE



COD. TEMP
MELANZANA PASTELLO
PASTEL AUBERGINE

SPECCHI MIRRORS

SPECCHIO MIRROR



COD. STSP
SPECCHIO
MIRROR



COD. SESP
SPECCHIO
EXTRACHAIRO
EXTRALIGHT
MIRROR

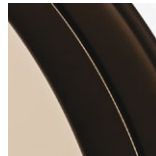

COD. SBSP
SPECCHIO BRONZO
BRONZED MIRROR



COD. SFSP
SPECCHIO FUMÉ
SMOKED MIRROR

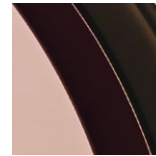

COD. SRSP
SPECCHIO ROSA
ROSE MIRROR

SPECCHI SATINATO SANDED MIRROR

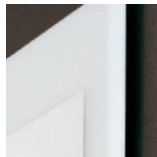

COD. STSA
SPECCHIO SATINATO
SANDED MIRROR

SPECCHIO ACIDATO FROSTED MIRROR



COD. SEAC
SPECCHIO
EXTRACHAIRO
ACIDATO
EXTRALIGHT
FROSTED MIRROR

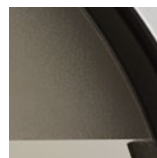

COD. SBAC
SPECCHIO
BRONZO ACIDATO
BRONZED
FROSTED MIRROR

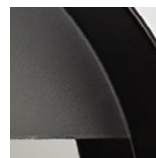

COD. SFAC
SPECCHIO FUMÉ
ACIDATO
SMOKED
FROSTED MIRROR

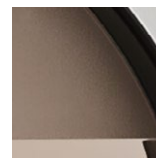

COD. SRAC
SPECCHIO ROSA
ACIDATO
ROSE FROSTED
MIRROR

LAMINATI E LEGNO LAMINATES AND WOOD

HPL HIGH PRESSURE LAMINATE



COD. HB
BIANCO - BORDO NERO
WHITE - BLACK EDGE



COD. HN
NERO
BLACK



COD. H4
BIANCO - BORDO BIANCO
WHITE - WHITE EDGE

CERAMICA CERAMIC

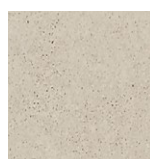

COD. CS
CERAMICA SALE
SALE CERAMIC



COD. CR
CERAMICA ROCCIA
ROCCIA CERAMIC

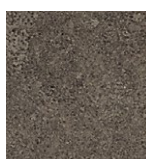

COD. CP
CERAMICA PIOMBO
PIOMBO CERAMIC

LEGNO WOOD

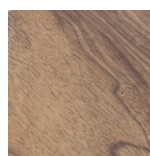

COD. NC
NOCE CANALETTO
CANALETTO
WALNUT



COD. LB
BIANCO LUCIDO
POLISHED WHITE

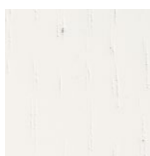

COD. BI
ROVERE TINTO BIANCO
PORO APERTO OAK
STAINED WHITE OPE-
NED PORES

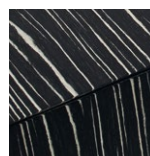

COD. ZN
ZEBRATO NERO
BLACK WITH WHITE
STRIPES

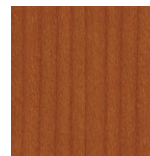

COD. CL
CILIEGIO
CHERRY WOOD

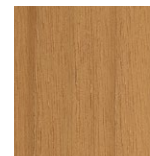

COD. NO
NOCE
WALNUT WOOD

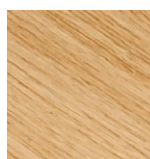

COD. RN
ROVERE NATURALE
NATURAL OAK

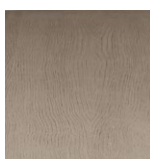

COD. RG
ROVERE TINTO
GRIGIO
GREY LACQUERED
OAK

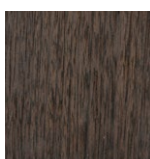

COD. WG
ROVERE TINTO WENGÈ
OAK STAINED WENGÈ



COD. WF
FRASSINO TINTO
WENGÈ
ASH STAINED
WENGÈ

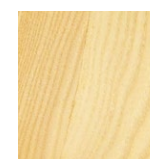

COD. RF
FRASSINO TINTO
ROVERE
ASH STAINED OAK

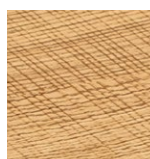

COD. R5
ROVERE NATURALE
TAGLIO SEGA
NATURAL OAK SAW
CUT

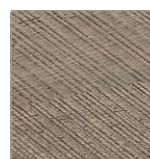

COD. R6
ROVERE TINTO
GRIGIO TAGLIO SEGA
GREY LACQUERED
OAK SAW CUT

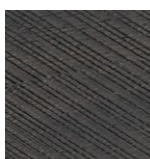

COD. R7
ROVERE TINTO WENGÈ
TAGLIO SEGA
WENGÈ LACQUERED
OAK SAW CUT

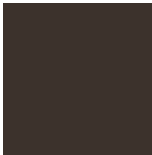

COD. FC
CAFFÈ
MOCHA



COD. FB
BIANCO
WHITE



COD. LC
CROMO LUCIDO
POLISHED CHROME

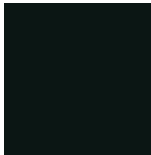

COD. FN
NERO
BLACK

PELLE FIORE, ECOPELLE E CUOIO

SOFT LEATHER, FAKE LEATHER AND LEATHER

CAT. PF

Pelle fiore
Soft leather

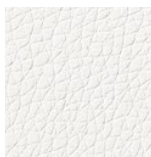

COD. P50
BIANCO
WHITE



COD. P51
PANNA
OFF-WHITE

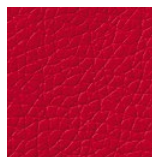

COD. P52
ROSSO
RED

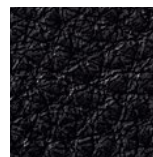

COD. P53
NERO
BLACK

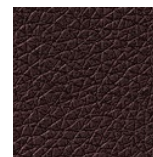

COD. P54
CAFFÈ
MOCHA

CAT. EP

Ecopelle
Fake leather

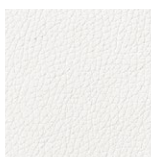

COD. E01
BIANCO
WHITE



COD. E02
PANNA
OFF-WHITE



COD. E03
ROSSO
RED

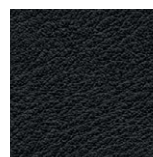

COD. E04
NERO
BLACK



COD. E05
CAFFÈ
MOCHA



COD. E06
ARANCIONE
ORANGE

CAT. CU

Cuoio
Leather

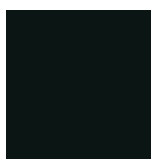

COD. C05
NERO
BLACK



COD. C14
CRETA
CLAY



COD. C07
CAFFÈ
MOCHA



COD. C08
ROSSO GRANATA
"GRANATA" RED



COD. C12
AVORIO CHIARO
LIGHT IVORY

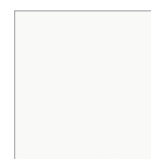

COD. C11
BIANCO
WHITE

I prezzi della collezione "Sovet Italia" sono resi noti dal presente listino e sono espressi in Euro IVA esclusa. Le proposte o commissioni d'ordine sono da intendersi sempre "salvo approvazione" di Sovet Srl. Nessun danno diretto o indiretto può essere richiesto per ritardata o mancata evasione dell'ordine. La merce viaggia a rischio e pericolo del committente se venduta "franco fabbrica". Eventuali contestazioni per rotture o danneggiamenti degli imballi devono essere segnalati sul documento di trasporto al momento dello scarico. Eventuali reclami per vizi o per qualunque altro motivo, devono pervenire nel termine di gg. 8 dal ricevimento della merce, a mezzo lettera raccomandata con ricevuta di ritorno. La validità formale di tale denuncia è subordinata al fatto che la stessa sia rivolta direttamente alla casa produttrice, e ciò anche in deroga all'art. 1745 del codice civile. Nessuna contestazione da parte del committente potrà in ogni caso giustificare rifiuti o ritardi nel pagamento: trascorso il termine sopraindicato non saranno ammesse eccezioni di inadempimento o di risoluzione né domande riconvenzionali. Qualsiasi reclamo non sarà procedibile se non previo pagamento dell'intero prezzo di tutte le fatture ancorché non scadute. Non si accettano resi di merce se non preventivamente autorizzati da Sovet Srl. Anche in caso di contestazione di qualsiasi genere, Sovet Srl ha diritto di richiedere l'integrale pagamento della fornitura con l'addebito degli interessi calcolati al tasso bancario vigente maggiorato di 5 punti entro il limite massimo consentito dalla legge 7 marzo, n.108 - "disposizioni in materia di usura". Sono ritenuti validi soltanto i pagamenti effettuati direttamente a Sovet srl. La merce rimane, fino al totale suo pagamento, di proprietà di Sovet srl, che ha facoltà di ritirarla. Il materiale consegnato deve essere conservato a cura del cliente in ambiente idoneo. In particolare, l'ambiente di conservazione deve essere asciutto (basso tasso di umidità), ed il materiale deve essere protetto dall'acqua e dai raggi solari diretti. Sovet Srl declina ogni responsabilità per l'errato montaggio in loco dei suoi oggetti d'arredamento in difformità rispetto alle relative istruzioni di montaggio. Pur nel rispetto della legge in vigore sulla responsabilità da prodotto difettoso, decliniamo qualsiasi responsabilità in merito all'utilizzo improprio a cui il cliente destina i nostri prodotti rispetto alle specifiche definite. Non tutti gli articoli a catalogo possono essere utilizzati in luogo pubblico; contattare Sovet Srl per le autorizzazioni del caso. Rimane a carico del rivenditore valutare la conformità del prodotto alle leggi vigenti nei paesi di destinazione (per il corretto impiego del prodotto raccomandiamo la lettura della scheda tecnica del prodotto). La conformità "al campione" sia per la prima che per le successive forniture non va intesa in senso restrittivo, giacché sussistono i margini di tolleranza di regola riconosciuti per i vari materiali impiegati. Sovet Srl si riserva di apportare modifiche strutturali senza obbligo di preavviso allo scopo di migliorare il prodotto. Ad ogni effetto legale o per qualsiasi controversia derivante dal rapporto, il foro competente è quello di Treviso. Agli ordini pervenuti saranno applicate le condizioni di vendita, lo sconto, le spese di trasporto e l'eventuale maggiorazione per imballo su cassa in vigore all'atto dell'acquisizione dell'ordine, salvo diversa approvazione di Sovet Srl. Articoli, misure, colori disponibili sono solo quelli riportati nel presente listino prezzi, altre misure e finiture su richiesta.

Prices of "Sovet Italia" collection are published in this price-list for the general public. They are expressed in Euro, value added tax (VAT) excluded. Proposals or order commissions are always "excepting approval" of Sovet Srl. Delivery terms specified in any document or statement shall be merely for guidance. Our company is not liable for missing merchandise or breakage. Goods travel at purchaser's risk if sold 'ex works'. Possible objections for package breakage or damage must be made to the shipper or carrier and have to be marked on the delivery note, when unloading. Possible claims for defects or any other reason must be sent to our headquarter within 8 days from receipt of the goods by registered letter with return receipt. The formal validity of this complaint is subjected to the fact that the same claim must be directly addressed to the manufacturer, even derogating article no.1745 of the Italian civil code. Any objection of the purchaser may not justify payment refusals or delays: once the 8 days term expires, Sovet Srl will not accept any exception for default, resolution or counterclaims. No returns of merchandise shall be accepted unless they have been previously authorized in writing by the company. Possible claims will be closed only after the payment of the total amount of all invoices, even not expired. In case of claims Sovet Srl always has the right to require the total payment of the goods plus the charge of the related interests on the arrears (considering the relevant banking rate increased of 5 points and within the maximum limit admitted by law no.108, dated 7th March, "anti-usury dispositions"). Payments must be made directly to Sovet Srl and they are the only valid. Goods remain of Sovet's property until Sovet Srl receive the full payment of the invoice; until that Sovet Srl can collect the goods any time. Delivered goods shall be stocked by the customers in a suitable place; in particular, the warehouse should be dry or with a low rate of humidity, and the merchandise shall be protected from water or direct sun rays. Sovet declines any responsibility for incorrect assembly in loco for furnishing articles. Even following the relevant rules about the responsibility in case of defected merchandise, Sovet Srl refuses any responsibility concerning the incorrect use of its goods. The conformity to the samples both for the first and the following deliveries has not to be intended in a restrictive sense, because of the tolerance margin normally admitted for the different materials employed. Not all the articles of the catalogue can be used in public places; please contact Sovet Srl for authorisation. It is the retailer's responsibility to evaluate the conformity of the product to the laws in force in the country of destination. (for a proper use please read the technical data sheet of the product). Measures or colours are indicative since it is technically impossible to keep these perfectly constant over a period of time. Sovet Srl reserves on his own, to apport structural variations, without obligation of notice them. The court of Treviso shall have jurisdiction over any disputes. The delivery terms, the discount, the freight charges and the possible surcharge for the packaging on wooden crate which would be applied to the orders will be the ones in force at the order receipt. Available articles, measures and colours are contemplated in this price-list. Other sizes and finishes can be required.

Les prix de la collection "Sovet Italia" sont exprimés en Euro, hors TVA. Les propositions de commande sont toujours entendues «sous approbation» de Sovet Srl. Aucun dédommagement direct ou indirect ne pourra être réclamé pour un quelconque retard ou non livraison de la commande. La marchandise est expédiée aux risques et périls de l'acheteur si elle est vendue «franco usine». Les éventuelles contestations pour rupture ou endommagement des emballages doivent impérativement être signalées sur le bon de livraison au moment du déchargement. Les éventuelles réclamations pour vice de fabrication ou pour tout autre motif devront être formulées dans un délai de 8 (huit) jours de la réception de la marchandise, par lettre recommandée avec accusé de réception. La validité formelle de la réclamation est subordonnée au fait qu'elle soit adressée directement au producteur, et ceci même en dérogation à l'art.1745 du code civil. Aucune contestation de la part de l'acheteur ne pourra justifier un refus ou retard de paiement. Passé le délai susmentionné, aucune exception de non-respect des clauses ou d'annulation ne sera admise. Aucune réclamation ne sera prise en compte avant le paiement intégral de toutes les factures y compris celles non échues. Aucun retour de marchandise ne sera accepté sans autorisation préalable de Sovet Srl. Même en cas de contestation de quelque sorte que ce soit, Sovet Srl a le droit de réclamer le paiement intégral de la fourniture majoré des intérêts calculés au taux bancaire en vigueur majoré de 5 points dans la limite maximum consentie par la loi n°108 du 7 mars - «disposition en matière d'usure». Seuls les paiements effectués directement à Sovet Srl sont reconnus valables et effectifs. Jusqu'à son paiement intégral, la marchandise reste propriété de Sovet Srl qui a la faculté de la reprendre. La marchandise livrée doit être conservée par le client dans un lieu adéquat. En particulier, l'endroit devra être sec (faible taux d'humidité) et la marchandise protégée de l'eau et des rayons directs du soleil. Sovet Srl décline toute responsabilité pour le montage erroné par les clients de ses articles d'ameublement, qui ne soit pas conforme aux instructions de montage. Bien que respectueux de la loi en vigueur sur la responsabilité pour un produit défectueux, nous déclinons toute responsabilité quant à une utilisation inappropriée du produit par le client par rapport aux spécifications définies. Pas les articles du catalogue ne peuvent pas être utilisés dans des lieux publics. prière de contacter Sovet Srl pour les autorisations. L'évaluation de la conformité du produit aux lois et dispositions en vigueur dans les différents pays de destination est à la charge du revendeur (pour la correcte utilisation des produits, nous recommandons une lecture attentive de la fiche technique du produit). La conformité «à l'échantillon» tant pour la première fourniture que pour les suivantes ne peut pas être considérée au sens restrictif car il existe des marges de tolérance reconnues et acceptables pour les différents matériaux employés. Sovet Srl se réserve le droit d'apporter des modifications structurales dans le but d'améliorer ses produits, sans obligation de préavis. A tous les effets légaux, et/ou pour toute controverse dérivant du rapport de travail, le seul tribunal de Treviso sera compétent. Les conditions de vente, la remise, les frais de port et l'éventuelle augmentation pour l'emballage en caisse en bois seront celles en vigueur au moment de l'acquisition de la commande, sauf diverse approbation de Sovet Srl. Seuls les articles, mesures, couleurs et finitions reportés dans ce tarif sont disponibles. Autres finitions et mesures sur requête.

Los precios de la colección "Sovet Italia" son en Euro, IVA no incluido. Las propuestas de pedido han de ser aprobadas por parte de Sovet Srl. Ninguna compensación directa o indirecta podrá ser reclamada por motivos de retraso o falta de entrega del pedido. El genero será expedido por cuenta y riesgo del comprador si la venta se realiza «franco fabrica». Las roturas o destrozos en el embalaje deben ser indicadas en el albarán en el momento de la descarga y recepción de los pedidos. Las reclamaciones por fallos de fabricación o cualquier otro motivo imputable al proceso productivo, deberán ser notificadas a Sovet Srl, en un plazo máximo de 8 (ocho) días después de la recepción de la mercancía mediante carta certificada con acuse de recibo. Para que tengan validez formal, se deberá enviar la reclamación directamente al proveedor, en cumplimiento del art.1745 del código civil. Ninguna contestación por parte del comprador podrá justificar el incumplimiento o el retraso en el pago. Transcurrido el plazo arriba indicado, no se admitirán faltas de acatamiento o anulación de las clausulas aquí indicadas. Ninguna reclamación será considerada antes del pago integral de todas las facturas, incluidas las de plazo no vencido. Ninguna devolución de mercancía sera aceptada sin previa autorización de Sovet Srl. Incluido cualquier tipo de contestación, Sovet srl puede reclamar el pago integral del genero mas los intereses calculados a la tasa bancaria vigente recargada en 5 puntos dentro del limite máximo autorizado por ley n°108 del 7 de marzo - «disposición en tema de usura». Solo los pagos enviados directamente a Sovet srl se consideraran validos y efectivos. Hasta su pago por entero, sino fuera así la mercancía remane propiedad de Sovet Srl, que tiene el derecho de recogerla. El comprador debe mantener el género entregado en un lugar apropiado. En particular, el lugar deberá ser seco (bajo porcentaje de humedad ambiental) y protegido del agua y de los rayos directos del sol. Sovet srl rehusa cualquier responsabilidad sobre daño en la mercancía provocado por un montaje erróneo de la misma por parte de los clientes, motivado por una falta de seguimiento de las instrucciones de montaje. Aunque respetuosos con la ley vigente sobre responsabilidad de un producto defectuoso, rehusamos cualquier responsabilidad por defecto del producto motivada por una utilización inapropiada del mismo por parte del cliente con relación a las especificaciones definidas. Los artículos del catalogo no pueden ser utilizados en lugares públicos. Contactar a Sovet Srl para usos distintos del estrictamente privado. La evaluación de la conformidad del producto a las leyes y disposiciones vigentes en los varios países de destinación corre a cargo del revendedor (para la correcta utilización de los productos, se recomienda leer muy atentamente las fichas técnicas). No se puede considerar la conformidad «de la muestra» en un sentido estricto, tanto de la primera entrega como de las siguientes, debido a ya margenes de tolerancia convenidos y aceptados para los materiales empleados. Sovet Srl se reserva el derecho de aportar modificaciones estructurales con el fin de mejorar sus productos sin obligación de aviso previo. A todos los efectos legales, y para cualquiera controversia incluyendo la relación de trabajo, solo el tribunal de Treviso será competente. Las condiciones de venta, el descuento, los portes y el eventual incremento por embalaje en caja de madera serán los vigentes en el momento de la recepción del pedido, salvo que se apruebe algo distinto por parte de Sovet Srl. Los artículos, las medidas, los colores y los acabados de esta tarifa están disponibles. Sin embargo se pueden pedir otras medidas y acabados.

SOVETITALIA

So.ve.t

Società Vetraria Trevigiana Srl

Via Emilio Salgari, 1/A
31056 Biancade, Treviso - Italy

TEL. +39 0422 848 030

FAX +39 0422 848 032

sovet@sovet.com

www.sovet.com

LE IMMAGINI ED I CONTENUTI RIPORTATI NEL PRESENTE CATALOGO SI INTENDONO DI PROPRIETÀ ESCLUSIVA DI SOVET, PERTANTO È VIETATO QUALSIASI TIPO DI RIPRODUZIONE.

THE PICTURES AND TEXTS IN THIS CATALOGUE ARE OF EXCLUSIVE PROPERTY OF SOVET. REPRODUCTION, BY WHATEVER MEANS, IS FORBIDDEN.

AZIENDA CERTIFICATA UNI EN ISO 9001:2008

CERTIFIED QUALITY SYSTEM UNI EN ISO 9001:2008

